

# SHARP ELECTRONIC ORGANIZER

SERIELLES INTERFACE

SPEZIFIKATION

FÜR

IQ-7000  
IQ-7100M

SHARP ELECTRONICS (EUROPE)

## Introduction

This document is intended to provide sufficient information for programmers to write software for devices to communicate with the serial port on the Sharp Electric Organizer in order to read and write data into the Sharp Electric Organizer memory.

## Physical Connection

The 15-pin serial connector on the Sharp Electric Organizer works at a voltage level of between 3.8V and 6.3V and so needs a level converter to change the levels to the RS-232C standard. The recommended way to do this is to use one of the Sharp level converter cables, either the CE-132T with separate power supply, or the CE-133T which is powered from the host RS-232C port.

The Sharp Electric Organizer serial interface has a baud rate of 9600bps, 8 data bits, 1 stop bit, no parity and Xon/Xoff control.

## Data Transfer Protocol

The attached appendix gives the specification of the protocol to be used when communicating with the Sharp Electric Organizer.

## Liability

Sharp are not liable for any damage resulting from changes to the memory contents of the Sharp Electric Organizer caused by software written using the specification or any physical damage caused by connecting non-Sharp approved equipment to the Sharp Electric Organizer.

1. Connect the RS-232C terminal of the personal computer to the 15-pin serial port of the Sharp Electric Organizer using one of the Sharp level converter cables.
2. Run the PC-Link program in the personal computer.
3. Put the Sharp Electric Organizer into PC-Link mode by pressing "SHIFT" "OPTION" to bring up the option menu and then "4" to select PC-LINK. Then the display is as follow.

<PC LINK>

LINK READY  
TO QUIT  
PUSH "ON" KEY

4. Transfer data between Personal Computer and Sharp Electric Organizer using the specified protocol.
5. Press "ON" on the Sharp Electric Organizer to terminate the transfer.

1. Transferring List of Filenames

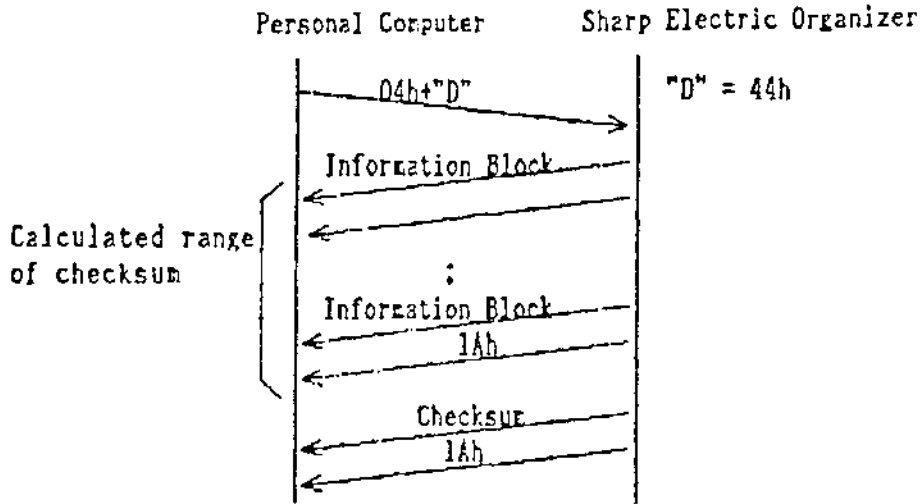

2. Transferring Data From Personal Computer To Sharp Electric Organizer

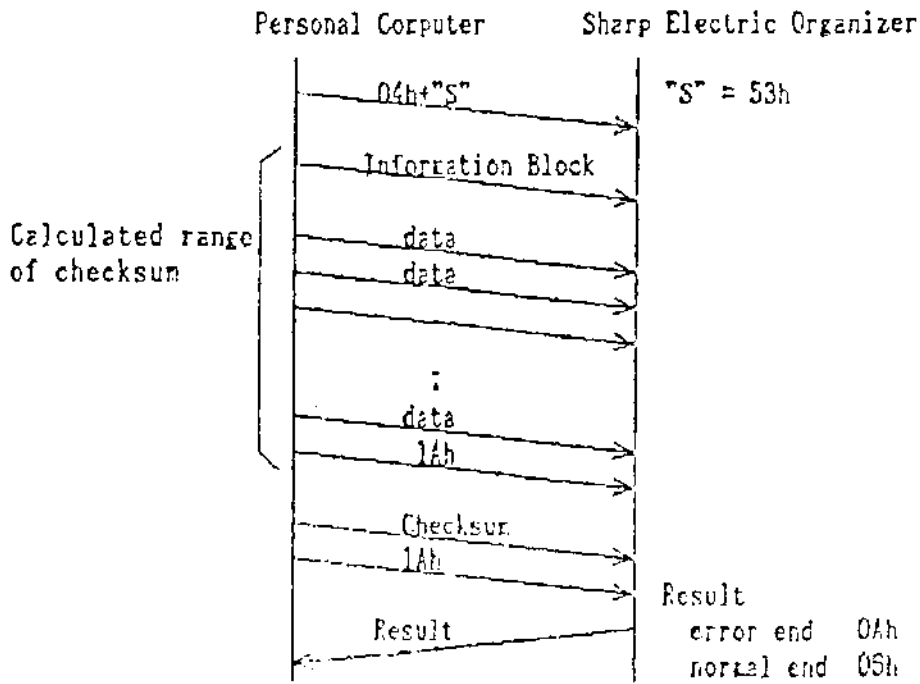

Personal Computer      Sharp Electric Organizer

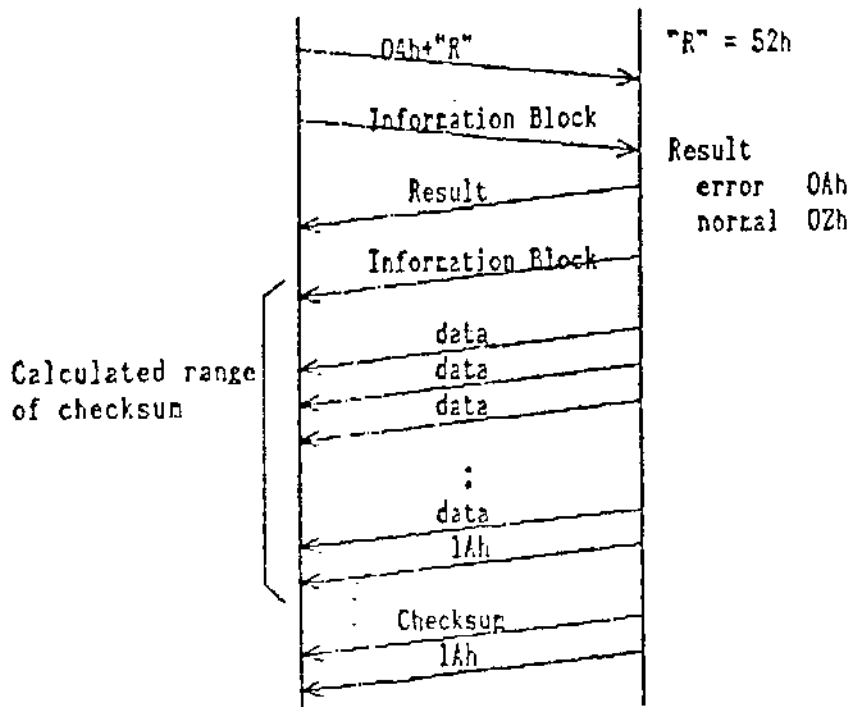

If the Personal Computer requests the Sharp Electric Organizer to send the data in an expansion RAM card when no expansion RAM card is present in the Sharp Electric Organizer, it returns "02h", "0Ah" to the Personal Computer as error information.

(If an ordinary error occurs, the Sharp Electric Organizer returns "0Ah" alone.)  
Accordingly, the software should be designed so that:

1. The Personal Computer does not request the Sharp Electric Organizer to send the data in any expansion RAM card when no expansion RAM card is inserted in the Sharp Electric Organizer.
2. The following error information handling is performed when data is transferred from the PC to the Sharp Electric Organizer.

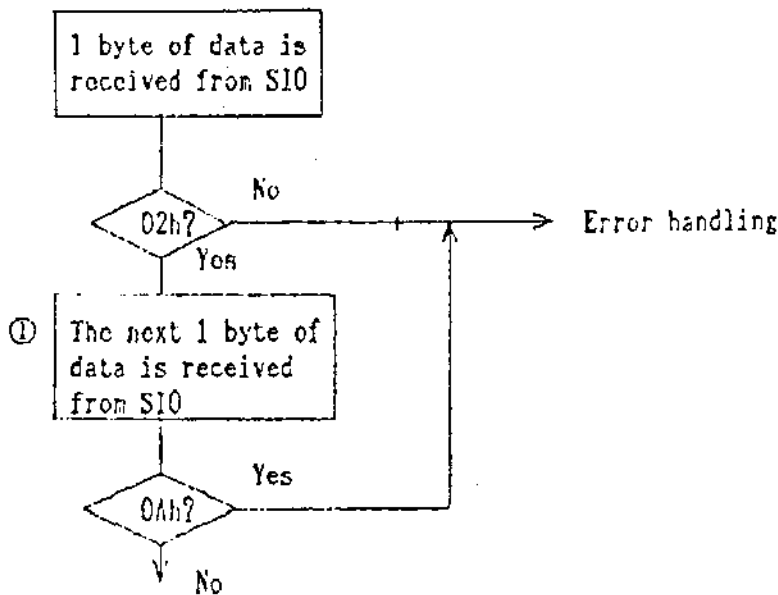

The data received in ① is regarded as the 1st byte of informative data, and the 2nd and subsequent bytes are received to continue data processing.

Application No.	Data code	00h	0Ah	Data Name	00h	0Ah
4byte	2byte			11byte		

1. Application Numbers and Data Name

Application Name	Application No.	Data Name
TEL1	0200	TEL 1
TEL2	0200	TEL 2
TEL3	0200	TEL 3
MEMO1	0300	MEMO 1
SCHEDULE1	0110	SCHEDULE1
ANNIVERSARY1	0110	ANN 1
ANNIVERSARY2	0110	ANN 2

a) Application No.  
The Application No. - 4 bytes - is expressed in hexadecimal.

b) Data Name  
The name of the application program is expressed in 11 bytes.

2. Data code

When loading data from Personal Computer to Sharp Electric Organizer

Code of Data code	Target RAM (Main or Expansion)	Appending or Overwriting
31h, 30h	Main	Appending
31h, 31h	Main	Overwriting
31h, 38h	Expansion	Appending
31h, 39h	Expansion	Overwriting

When saving data from Sharp Electric Organizer to Personal Computer

Code of Data code	Target RAM (Main or Expansion)	Appending or Overwriting
↓ 30h, 30h	Main	Appending
30h, 31h	Main	Overwriting
30h, 38h	Expansion	Appending
30h, 39h	Expansion	Overwriting

(note) Main: RAM in the main unit

Expansion: RAM in the expansion RAM card

(EX.) When loading data from Personal Computer to Sharp Electric Organizer in appending mode.

Data code 

31h	30h
1	0

TEL1  
Start 30h  
→ 31h

## A. CHECKSUM

### Calculating Checksum For Use With Data Transmission

Checksum is calculated using a simple addition principle. All characters except the header are included in the checksum calculation. The checksum is represented by hex 4 bytes in the standard low-high bytes format. Also the Checksum is followed by "0Dh", "0Ah".

(EX.) Checksum 8B02h  
Represented as "026B"

30h	32h	36h	42h	0Dh	0Ah
"0"	"2"	"6"	"B"		

TEL

Attrib.	Name	ODh	OAh	Number	ODh	OAh	Address	ODh	OAh
2bytes									

MEMO

Attrib.	Description	ODh	OAh
2bytes			

Schedule

Attrib.	Year	Month	Day	Start Time	End Time	Alarm Time	ODh	OAh	Description	ODh	OAh
	Hour	Minute	Hour	Minute	Hour	Minute					
2bytes	4	2	2	2	2	2	2	2			

Anniversary1

Attrib.	Month	Date	ODh	OAh	Description	ODh	OAh
2bytes	2	2					

Anniversary2

Attrib.	Month	Week	Day	ODh	OAh	Description	ODh	OAh
2bytes	2	1	1					

Week: The week is indicated by numbers 1 to 5.

Day: The days of the week are indicated by numbers 0 to 6 in sequence as follows:

- 0: Sunday    1: Monday    2: Tuesday    3: Wednesday
- 4: Thursday    5: Friday    6: Saturday

	Bit 7	6	5	4	3	2	1	0
	Secret mark	Alarm	Display mode					
Telephone	○		○					
Schedule	○	○	○					
Yeso	○		○					
Ann1			○					
Ann2			○					

Secret mark     1: Secret data  
                   0: Not secret data

Alarm            1: Alarm setting Yes  
                   0: Alarm setting No

Display mode    1: 4-line display  
                   0: 8-line display

## Reference Materials

1. The outline process of PC-LINK Software in the Sharp Electric Organizer.
2. The manual of CE-132T which is the RS-232C I/F cable for the Sharp Electric Organizer.
3. The manual of CE-133T which is the RS-232C I/F cable for the Sharp Electric Organizer.

- 1 PRINTER
- 2 UNIT TO UNIT
- 3 CASSETTE TAPE
- 4 PC LINK

NOTE) \* : In case of there is no application which is selected by information block from Personal Computer.

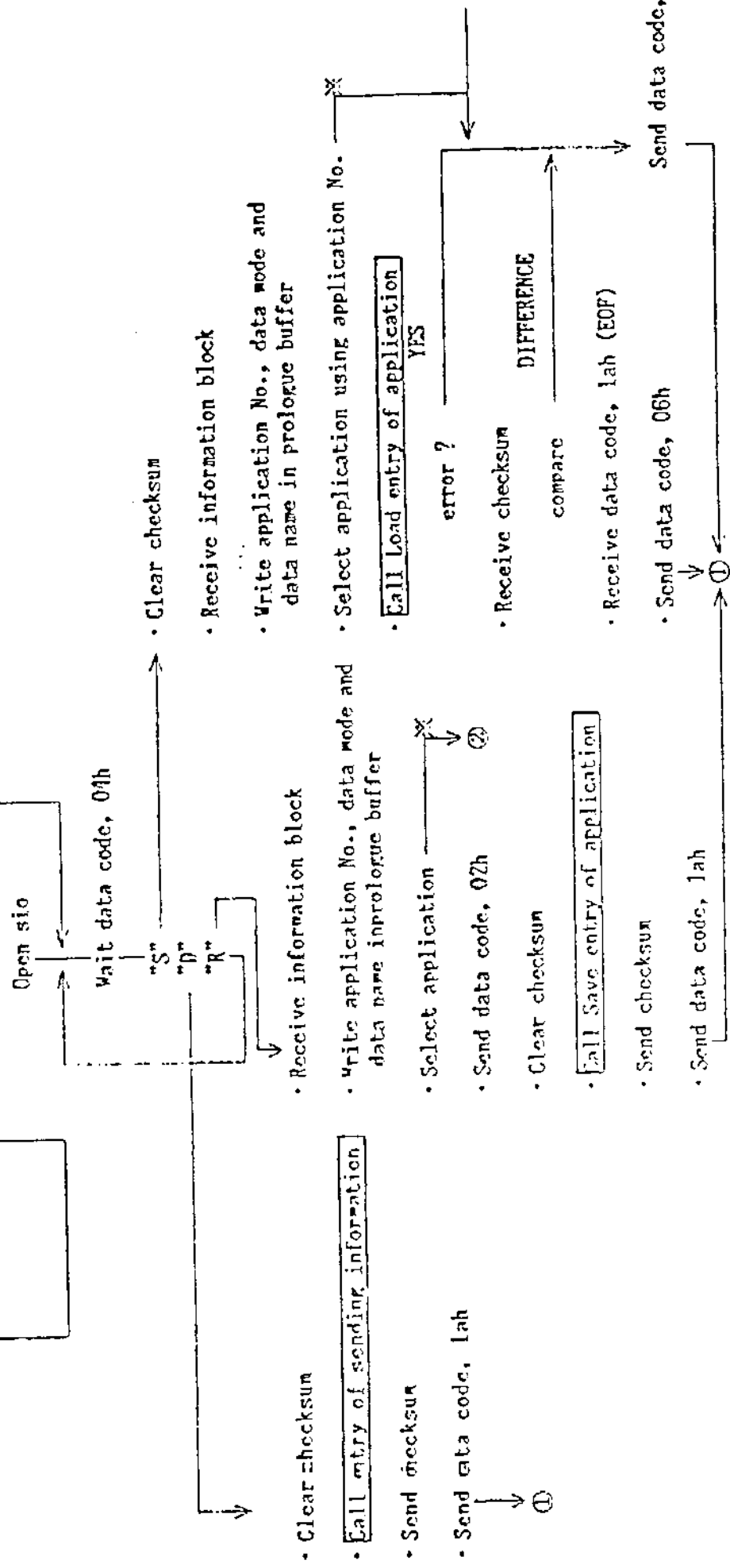

1. Information block

TEL

0	2	0	0	1	0	0D	0A	T	E	L	1	0D	0A						
30	32	30	30	31	30	0D	0A	54	45	4C	20	20	20	20	31	20	20	0D	0A

(HEX)

Application No.      Data mode      Data Name

↑                      ↑                      ↑

↳ Append code; the RAM in the main unit is the target.

MEMO

0	3	0	0	1	8	0D	0A	M	E	M	O	1	0D	0A						
30	33	30	30	31	38	0D	0A	4D	45	4D	4F	20	20	20	20	31	20	20	0D	0A

(HEX)

Application No.      Data mode      Data Name

↑                      ↑                      ↑

↳ Append code; the expansion RAM is the target.

Schedule

0	1	1	0	1	1	0D	0A	S	C	H	E	D	U	L	E	1	0D	0A		
30	31	31	30	31	31	0D	0A	53	43	48	45	44	55	4C	45	31	20	20	0D	0A

(HEX)

Application No.      Data mode      Data Name

↑                      ↑                      ↑

↳ Overwrite code; the RAM in the main unit is the target

Anniversary1

0	1	1	0	1	1	0D	0A	A	N	N	1	0D	0A							
30	31	31	30	31	31	0D	0A	41	4E	4E	20	20	20	20	20	31	20	20	0D	0A

(HEX)

Application No.      Data mode      Data Name

↑                      ↑                      ↑

↳ Overwrite code; the RAM in the main unit is the target

Anniversary2

0	1	1	0	1	1	0D	0A	A	N	N	2	0D	0A							
30	31	31	30	31	31	0D	0A	41	4E	4E	20	20	20	20	20	32	20	20	0D	0A

(HEX)

Application No.      Data mode      Data Name

↑                      ↑                      ↑

↳ Overwrite code; the RAM in the main unit is the target

2. Mode Data

TEL

00	Name (Ascii code)	0Dh	0Ah	Tel Number (Ascii code)	0Dh	0Ah	Address (Ascii code)	0Dh	0Ah
----	----------------------	-----	-----	----------------------------	-----	-----	-------------------------	-----	-----

30 30

Attribute: Secret mark No, 8-line display mode

MEMO

80	Description (Ascii code)	0Dh	0Ah
----	--------------------------	-----	-----

38 30

↳ Attribute: Secret mark Yes, 8-line display mode

Schedule

60	1	8	8	0	1	0	1	2	0	0	0	2	1	3	0	2	0	0	0	0Dh	0Ah
----	---	---	---	---	---	---	---	---	---	---	---	---	---	---	---	---	---	---	---	-----	-----

36 30 31 39 38 39 30 31 30 31 32 30 30 30 32 31 33 30 32 30 30 30

Year Month Day Hr. Min. Hr. Min. Hr. Min.  
(Start) (End) (Alarm)



Description(Ascii code)	0Dh	0Ah
-------------------------	-----	-----

↳ Attribute: Alarm Yes, 4-line display mode, Secret mark No

Anniversary1

00	0	8	2	1	0Dh	0Ah	Description	0Dh	0Ah
----	---	---	---	---	-----	-----	-------------	-----	-----

30 30 30 39 32 31

Month Day



↳ Attribute: 8-line display mode

Anniversary2

00	1	2	3	2	0Dh	0Ah	Description	0Dh	0Ah
----	---	---	---	---	-----	-----	-------------	-----	-----

30 30 31 32 33 32

Month

↳ Day

↳ Week



↳ Attribute: 8-line display mode

## V. Signal Used In The Serial I/O Interface

The Sharp Electric Organizer is equipped with a 15-pin connector for the serial I/O interface.

The pins used and their signals are described below.

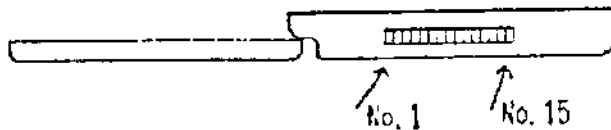

Pin No.	Name	Symbol	I/O	Function
1	Frame Ground	FG		Protective chassis ground
2	Send Data	SD	0	Outputs a DC data signal
3	Receive Data	RD	1	Inputs a DC data signal
4	Request to Send	RS	0	HIGH:Sends carrier
5	Clear to Send	CS	1	HIGH:Transmission enabled
6	Data Set Ready	DR	1	HIGH:Modem ready to send/receive
7	Signal Ground	SG		Reference 0 voltage for all signals
8	Carrier Detect	CD	1	HIGH:Carrier signal received
9				
10		VC1		Power supply
11	Receive Ready	RR	0	HIGH:Receive enabled
12				
13		VC2		Power supply
14	Data Terminal Ready	ER	0	HIGH:Local terminal ready
15				

### Notes

- (1) HIGH:VC voltage level; LOW:SG voltage level.
- (2) Sharp Electric Organizer uses CMOS components. Application of voltage exceeding the allowable range, i.e., voltage level between SG and VC, may damage the Sharp Electric Organizer.
- (3) VC1, VC2 is connected in the unit.  
Voltage level is 3.6V~6.3V.

SERIAL INTERFACE SPECIFICATION  
FOR  
SHARP NEW OZ/IQ  
(Electric Organizer)

March 1990  
SHARP CORPORATION

The difference between NEW "PC LINK PROTOCOL" and Current "PC LINK PROTOCOL"

1. Addition of "Information Block"  
Information Block of Current "OZ/IQ" → Information Block1  
The Information Block1 structure is the same structure as Current PC-LINK Information Block  
Additional Information Block of "NEW OZ/IQ" → Information Block2
2. Addition of "COMMAND"  
Refer to "NEW PC LINK COMMAND"
3. Addition of "ERROR INFORMATION"  
Refer to "ERROR INFORMATION"

New PC LINK Support Command

COMMAND	Current OZ/IQ	NEW OZ/IQ	CONTENTS
D	○	○	Application name
S	○	○	Transfer data from personal computer to OZ/IQ
R	○	○	Transfer data from OZ/IQ to personal computer
I		○	Transfer Index data from OZ/IQ
C		○	Data deletion
T		○	Time set
U		○	Transfer User name from OZ/IQ
Z		○	Transfer System condition from OZ/IQ

Application Numbers and Data name

Application Name	Application No.	Data Name	Current 02/10	NEW 02/10
SCHEDULE1	0110	SCHEDULE1	○	○
PERIOD SCHEDULE	0110	PERIOD 1		○
ANNIVERSARY1	0110	ANN 1		○
ANNIVERSARY2	0110	ANN 1	○	○
DAILY ALARM	0110	D ALARM 1	○	○
TEL FILE NAME1	0200	TEL FILE1		○
TEL FILE NAME2	0200	TEL FILE2		○
TEL FILE NAME3	0200	TEL FILE3		○
TEL FREE MEMO TITLE1	0200	TEL FREE1		○
TEL FREE MEMO TITLE2	0200	TEL FREE2		○
TEL FREE MEMO TITLE3	0200	TEL FREE3		○
TEL1	0200	TEL 1	○	○
TEL2	0200	TEL 2	○	○
TEL3	0200	TEL 3	○	○
MEMO1	0300	MEMO 1	○	○
OUTLINE	1000	OUTLINE 1		○
BUSI FREE MEMO TITLE	1E00	BUS FREE1		○
BUSINESS CARD	1E00	BUSINESS1		○
USER'S DICTIONARY	1F00	USER'S DIC		○

Error Information

ERROR CODE	ERROR CONTENTS
41h	I/O DEVICE ERROR
42h	MEMORY OVER
43h	BUFFER OVER
44h	DATA ERROR
46h	SECRET MODE
48h	APPLICATION NOT FOUND
49h	DATA NOT FOUND
4Ah	DATA MODIFIED
4Bh	COMMAND NOT SUPPORT
FEh	LOW BATTERY
FFh	ON/BREAK KEY

Data Transfer Protocol On The Electric Organizer Using PC-LINK

1. Transferring List of File name

• Level I (Current PC-LINK PROTOCOL)

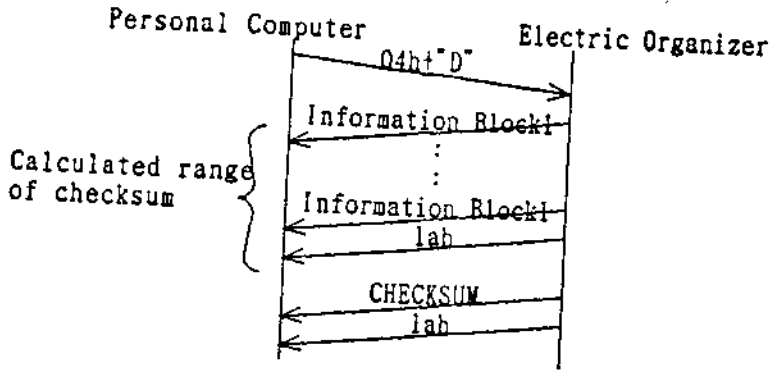

• Level II (NEW PC-LINK PROTOCOL)

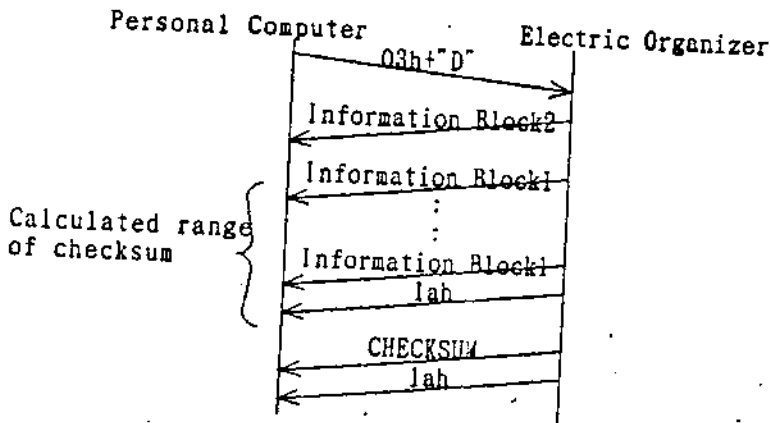

• Information Block2 of Data Transferring List of File name

Appli. NO.			
0	0	0	0
09	LINK09	MODEL NAME	090DOA
	MODE		

Application NO. : 4 bytes

Application NO. of Information Block2 is "0000".

LINK MODE: 2 bytes

LINK MODE is "00".

MODEL NAME: Changeable data size

MODEL NAME is terminated by "09h"

MAX SIZE is 40 bytes

(SAMPLE DATA)

30	30	30	30	09	30	30	09	57	49	5A	41	52	44	09	0D	0A
0	0	0	0	0	0	0	0	W	I	Z	A	R	D			

2. Transferring Data From Personal Computer To Electric Organizer

• Level I (Current PC-LINK PROTOCOL)

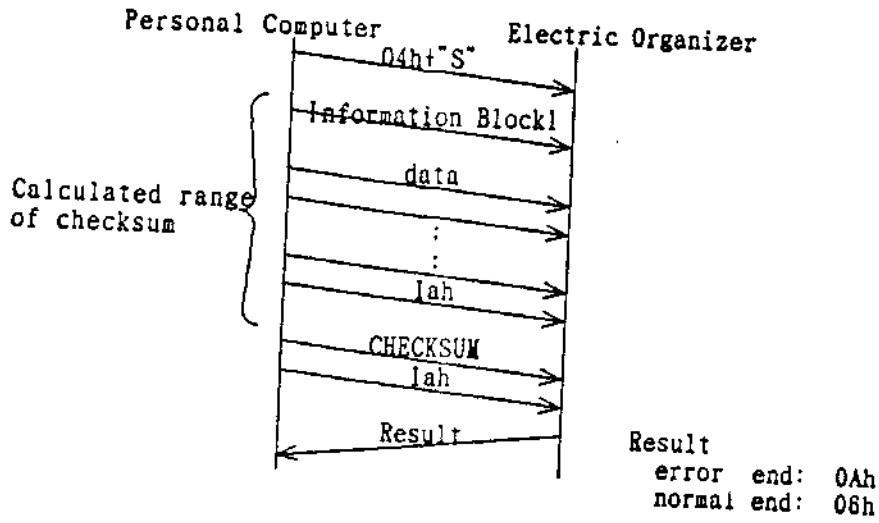

• Level II (NEW PC-LINK PROTOCOL)

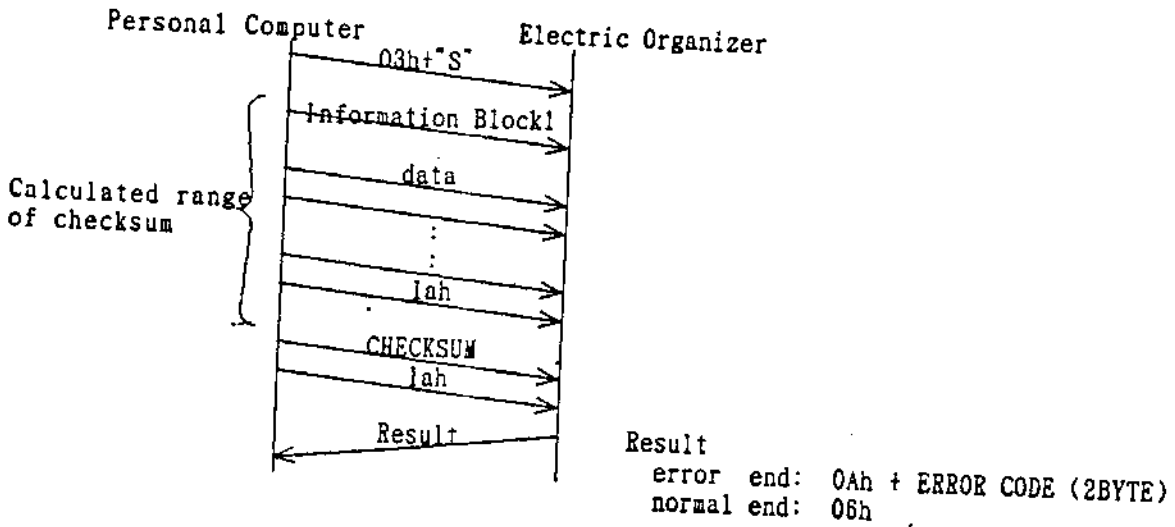

### 3. Transferring Data From The Electric Organizer to Personal Computer

In Transferring data from Electric Organizer, "Level I (Current PC-LINK PROTOCOL)" support only transferring block data and "Level II (NEW PC-LINK PROTOCOL)" support transferring block data and one data.

#### • Level I (Current PC-LINK PROTOCOL)

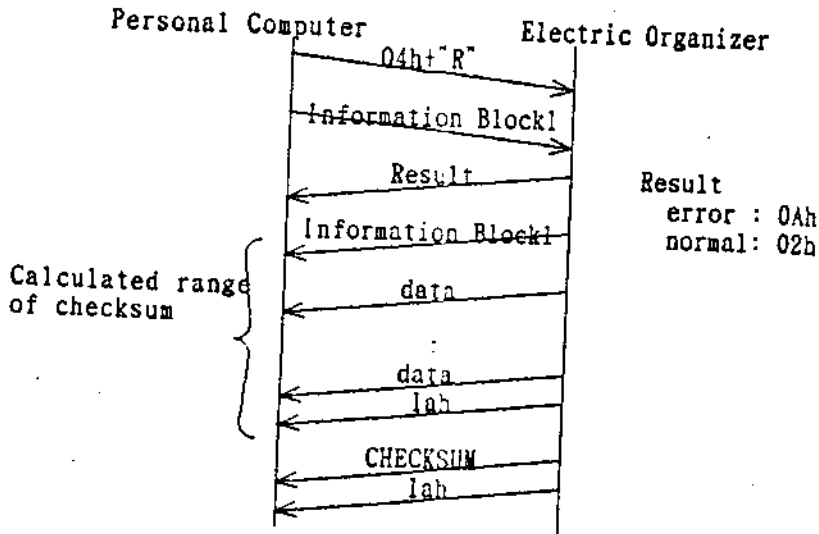

#### • Level II (NEW PC-LINK PROTOCOL)

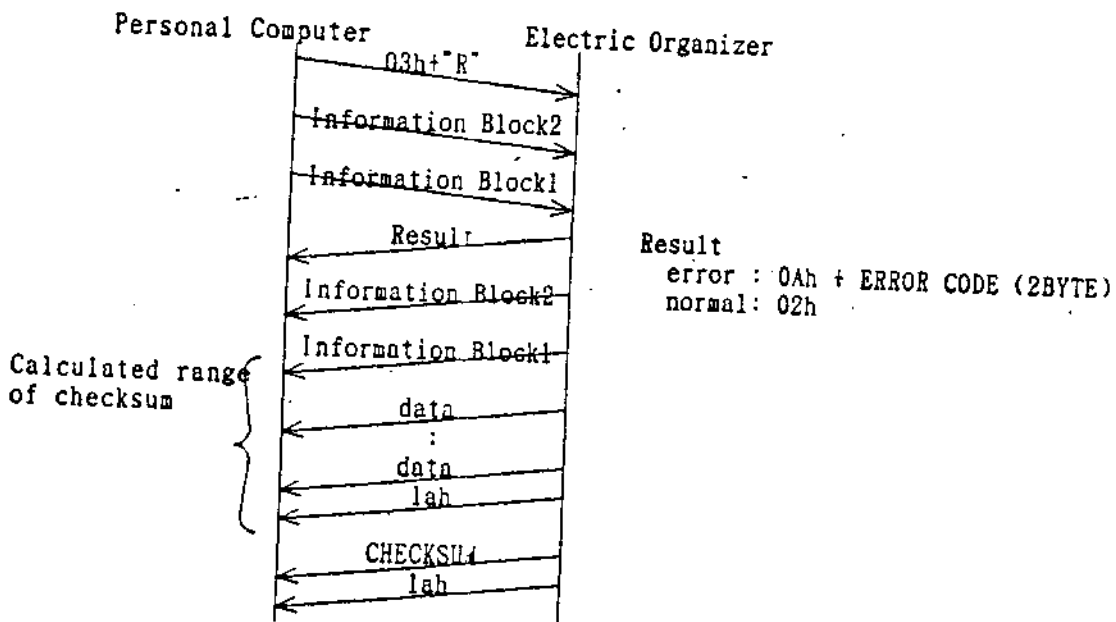

• Information Block2 of Transferring Data From The Electric Organizer

0	0	0	0	09	RECORD NO.	09	CHECK MODE	CHECKSUM	090D0A
---	---	---	---	----	------------	----	------------	----------	--------

RECORD NO. : 4 bytes

The "RECORD NO." is represented by hex 4 bytes in the standard low-high bytes format.

0000 : block data  
0001~ffff: one data

CHECK MODE : 2 bytes

00: check checksum  
01: not check checksum

CHECKSUM : 6 bytes

The checksum is represented by hex 6 bytes in the standard low-mid-high bytes format.

One record data is specified by "RECORD NO." and "CHECKSUM" of Index data.

Each one record data of application file have the characteristic CHECKSUM.

(SAMPLE DATA)

3	0	3	0	3	0	0	9	B	1	4	1	0	0	0	0	9	3	0	3	1	3	4	3	5	3	2	3	3	3	0	3	1	0	9	0	D	0	A	
0	0	0	0	1	A	0	0	4	5	2	3	0	1																										

In this sample data the Electric Organizer transfer following data to Personal Computer.

RECORD NO. : 001Ah  
CHECK MODE : 01h  
CHECKSUM : 012345h

The 26 th record data of the file

Not check checksum

Checksum is "123435h"

This value is calculated by the Electric Organizer  
If the 26 th record data is modified, the value of checksum is changed.

4. Transferring Index Data from The Electric Organizer

• Level I (Current PC-LINK PROTOCOL)  
Not Support

• Level II (NEW PC-LINK PROTOCOL)

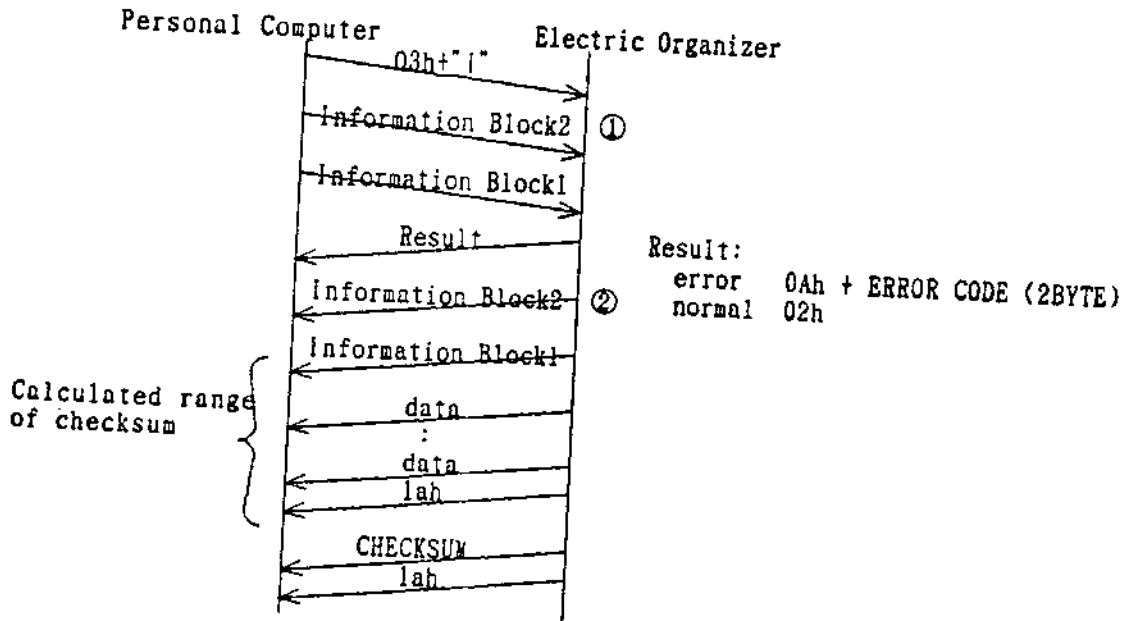

• Information Block2 ① of Transferring Index Data

0	0	0	0	09	RECORD	09	NUMBER	090D0Ah
					NO.		OF DATA	

RECORD NO. : 4 bytes  
First record NO. of index data

NUMBER OF DATA: 4 bytes  
Total number of index data

• Information Block2 ② of Transferring Index Data

0	0	0	0	09	DATA MAX	09	TOTAL	090D0Ah
					SIZE		NUMBER	

DATA MAX SIZE: 4 bytes  
Max size of each index data (40 bytes)

TOTAL NUMBER : 4 bytes  
Total record number of application file data

• DATA

RECORD NO.	09	Checksum	09	INDEX DATA	090D0Ah
------------	----	----------	----	------------	---------

- RECORD NO. : 4 bytes  
Number of record data
- CHECKSUM : 6 bytes  
The checksum is represented by hex 6 bytes in the standard low-mid-high bytes format.
- INDEX DATA : The "INDEX DATA" is a part of record data.  
Changeable data size (MAX 40 bytes)

(SAMPLE DATA)

• Information Block2 ①

30303030	09	30363030	09	30333030	090D0Ah
0 0 0 0		0 6 0 0		0 3 0 0	

The Electric Organizer transfer the index data of 6th record data, 7th record data and 8th record data to Personal Computer.

• Information Block2 ②

30303030	09	32383030	09	33373030	090D0Ah
0 0 0 0		2 8 0 0		3 7 0 0	

Index data max size are 0028h (40) bytes.  
There are 0037h (55) records in application file.

• DATA

30393030	09	1323334303	09	53414D504C4520494E444558	090D0Ah
0 9 0 0		1 2 3 4 0 1		SAMPLE INDEX	

This is the 9th record data of application file.  
The checksum of the 9th record data are "013412h".  
The index data of the 9th record data are "SAMPLE INDEX".

5. Data deletion

• Level I (Current PC-LINK PROTOCOL)  
Not support

• Level II (NEW PC-LINK PROTOCOL)

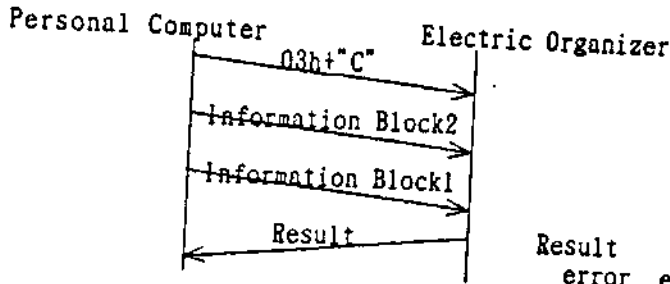

Result  
error end: 0Ah + ERROR CODE (2BYTE)  
normal end: 06h

• Information Block2

0	0	0	0	09	RECORD	09	CHECKSUM	090D0A
					NO.			

RECORD NO. : 4 bytes  
CHECKSUM : 6 bytes

(SAMPLE DATA)

30303030093634303009343533323031090D0A
0 0 0 0 6 4 . 0 0 4 5 3 2 0 1

The 100th record data is deleted.  
If "CHECKSUM" of 100th record data is not "13245h", the data is not deleted.

6. Time Setting

- Level I (Current PC-LINK PROTOCOL)  
Not support
- Level II (NEW PC-LINK PROTOCOL)

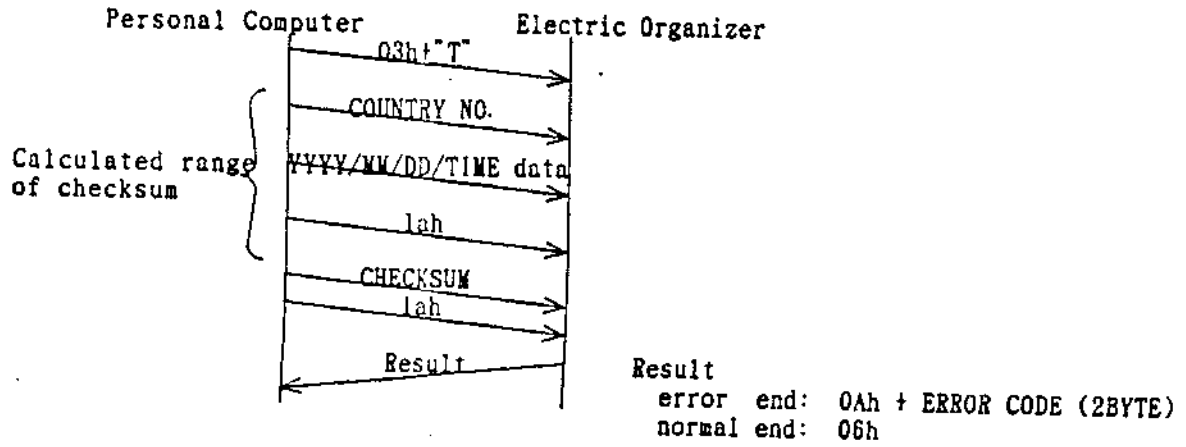

• COUNTRY NO.

Refer to COUNTRY NO. in addition to this manual.

COUNTRY NO.	00A
-------------	-----

• YYYY/MM/DD/TIME DATA

YYYYMMDDHHMM	00A
--------------	-----

(SAMPLE DATA)

HOME CITY : NEW YORK  
TIME : Sep. 14. 1988  
1:35 p.m.

423900	00A
--------	-----

B9h (185)

THE COUNTRY NO. 185 is NEW YORK

31393930303431373130313500	00A
198809141335	

Sep. 14. 1988  
1:35 p.m.

7. Transferring User Name from Electric Organizer

• Level I (Current PC-LINK PROTOCOL)  
Not support

• Level II (NEW PC-LINK PROTOCOL)

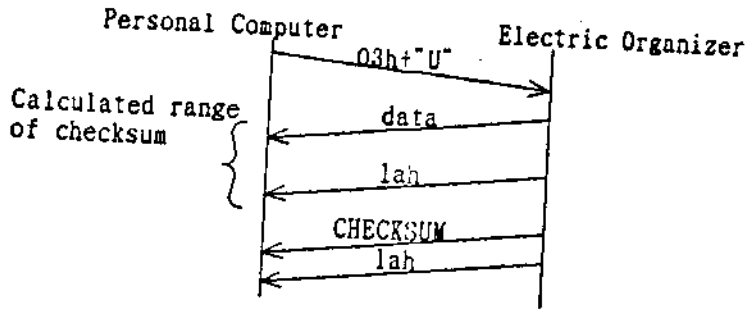

• DATA

Attrib.	Name	ODOAh	Number	ODOAh	Address	ODOAh
---------	------	-------	--------	-------	---------	-------

10. Transferring System Condition from Electric Organizer

• Level I (Current PC-LINK PROTOCOL)  
Not support

• Level II (NEW PC-LINK PROTOCOL)

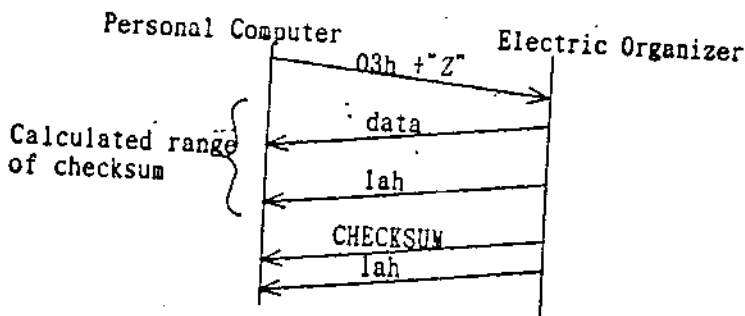

• DATA

SYSTEM STATE	ODOAh	LINK MODE	ODOAh	USED MEMORY	ODOAh	MEMORY CAPACITY	ODOAh
2 bytes		2 bytes		6 bytes		6 bytes	
LANGUAGE NO.	ODOAh	DISPLAY W SIZE	ODOAh	DISPLAY H SIZE	ODOAh	MODEL NAME	ODOAh
2 bytes		2 bytes		2 bytes		max 40 bytes	

SYSTEM STATE : 2 bytes

BIT 7 6 5 4 3 2 1 0

--	--	--	--	--	--	--	--

BIT 0 SECRET  
0: SECRET OFF  
1: SECRET ON

BIT 2 CALENDER DISPLAY MODE  
0: SUM → SAT  
1: MON → SUN

BIT 3 TIME DISPLAY MODE  
0: 24h MODE  
1: 12h MODE

BIT 4 DATE DISPLAY MODE  
0: MM/DD/YYYY  
1: DD/MM/YYYY

BIT 5 LANGUAGE MODE  
0: NOT SUPPORT MULTI LANGUAGE  
1: SUPPORT MULTI LANGUAGE

LINK MODE : 2 bytes  
This 2 bytes data are "0", "0".

MEMORY CAPACITY: 6 bytes  
Memory capacity for application data

USED MEMORY : 6 bytes  
The MEMORY CAPACITY and USED MEMORY are represented by hex 6 bytes in the standard low-mid-high bytes format.

LANGUAGE NO. : 2 bytes  
ENGLISH : 00h (30h.30h)  
GERMAN : 02h (30h.32h)  
FRENCH : 03h (30h.33h)  
ITALIAN : 04h (30h.34h)  
SPANISH : 05h (30h.35h)  
SWEDISH : 06h (30h.36h)  
FINNISH : 07h (30h.37h)

DISPLAY SIZE : 2 bytes  
The "DISPLAY SIZE" of NEW OZ/IQ is as follows.  
DISPLAY W SIZE : 28h  
DISPLAY H SIZE : 08h

MODEL NAME : MAX 40 bytes

## CHECKSUM

### Calculating Checksum For Use With Data Transmission

Checksum ( after "lah" ) is calculated using a simple addition principle. All characters except the header are included in the checksum calculation. The checksum is represented by hex 4 bytes in the standard low-high bytes format. also the checksum is followed by "0Dh", "0Ah".

(EX.) Checksum 6B02h  
Represented as "026B"

30h	32h	36h	42h	0Dh	0Ah
0	2	6	B		

Data Formats For Each Modes

1. SCHEDULE

A. SCHEDULE

Attrib.	START			END			ALARM		Description	ODOAh
	Year	Month	Day	Hour	Minute	Hour	Minute	Hour		
2 bytes	4	2	2	2	2	2	2	2	2	

(COMMENT)

Description max size is 2K bytes.

B. ANN1

Attrib.	Month	Day	ODOAh	Description	ODOAh
2 bytes	2	2			

(COMMENT)

Description max size is 512 bytes.

C. ANN2

Attrib.	Month	Week	Day	ODOAh	Description	ODOAh
2 bytes	2	2	2			

WEEK: The week is indicated by numbers 1 to 5.

DAY : The days of the week are indicated by numbers 0 to 6 in sequence as follows:

0: Sunday 1:Monday 2:Tuesday 3:Wednesday  
4: Thursday 5:Friday 6:Saturday

(COMMENT)

Description max size is 512 bytes.

D. Period schedule

Attrib.	START			END			ODOAh	Description	ODOAh
	Year	Month	Day	Year	Month	Day			
2 bytes	4	2	2	4	2	2			

(COMMENT)

Description max size is 512 bytes.

E. Daily alarm

Attrib.	Hour	Minute	ODOAh
2 bytes	2	2	

Attrib.	Name	0DOAh	Number	0DOAh	Address	0DOAh	...	...
---------	------	-------	--------	-------	---------	-------	-----	-----

2 bytes

Free Field1	0DOAh	Free Field2	0DOAh	Free Field3	0DOAh	Free field4	0DOAh	Free Field5	0DOAh
-------------	-------	-------------	-------	-------------	-------	-------------	-------	-------------	-------

(COMMENT)

Tel data max size is 2K bytes.

B. TEL FILE NAME

Attrib.	TEL FILE NAME	0DOAh
---------	---------------	-------

2 bytes            10 bytes

C. Free Field Title

Attrib.	Free Field Title1	0DOAh	Free Field Title2	0DOAh	Free Field Title3	0DOAh
---------	-------------------	-------	-------------------	-------	-------------------	-------

2 bytes

0DOAh	Free Field Title4	0DOAh	Free Field Title5	0DOAh
-------	-------------------	-------	-------------------	-------

(COMMENT)

Free Field Title size is 12 bytes.

3. Memo

Attrib.	Description	0DOAh
---------	-------------	-------

2 bytes

(COMMENT)

Description max size is 2K bytes.

#### 4. Outline

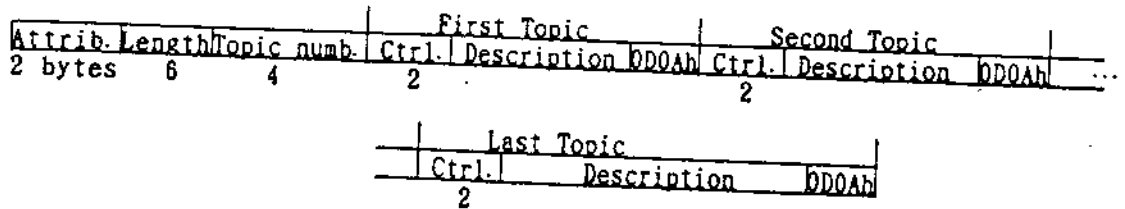

Attribute : 2 bytes  
 "SECRET" and "DISPLAY MODE" bit are available.

Length : 6 bytes  
 "Length" is represented by hex 6 bytes in the standard low-mid-high bytes format.

+ "2 bytes + Description bytes + 1 byte" (First Topic)  
 + "2 bytes + Description bytes + 1 byte" (Second Topic)  
 + "2 bytes + Description bytes + 1 byte" (Last Topic)

Topic number : 4 bytes  
 Number of Topic  
 "Topic number" is represented by hex 4 bytes in the standard low-high bytes format.

Ctrl. : 2 bytes  
 Attribute of Topic Description

First byte:

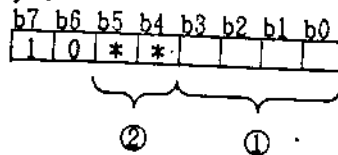

① : depth of topic (0 ~ 15)  
 Title (First Topic) : 0  
 ② : not fixed

Second byte:

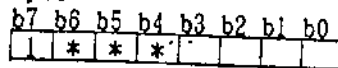

b0 : Display style bit  
 0: 1 line display mode  
 1: Full data display mode

b1 : Topic display mode bit  
 0: Display topic  
 1: Don't display topic

b2 : Child topic display mode bit  
 0: Display child topic  
 1: Don't display child topic

b3 : Child existence bit  
 0: Don't have a child  
 1: Have a child

b4-b6: Not fixed yet

(COMMENT)

Each topic Description max size is 2K bytes.

A. Business Card Data

Attrib.	Company	Division	Tel Number	Fax Number
---------	---------	----------	------------	------------

2 bytes

Address	Name	Position	Private Number
---------	------	----------	----------------

Free Field1	Free Field2	Free Field3	Free Field4	Free Field5
-------------	-------------	-------------	-------------	-------------

(COMMENT)

Company max size is 40 bytes.

Total max size of Division, Tel Number, Fax Number and Address is 512 bytes.

Total max size of Name, Private Number, Position and Free Fields is 1.5K bytes.

B. Free Field Title

Attrib.	Free Field Title1	Free Field Title2	Free Field Title3
---------	-------------------	-------------------	-------------------

2 bytes

Free Field Title4	Free Field Title5
-------------------	-------------------

(COMMENT)

Free Field Title size is 12 bytes.

6. User's Dictionary

Attrib.	data
---------	------

(COMMENT)

Max data size is 40 bytes.



SAMPLE DATA

1. Outline

•DATA

MEETING	--- 1st Topic (Title)	Length of contents
ELECTRONIC ORGANIZER	--- 2nd Topic	7
OZ-7000	--- 3rd Topic	20
HARD WARE	--- 4th Topic	7
SOFT WARE	--- 5th Topic	9
OZ-7100M	--- 6th Topic	9
HARD WARE	--- 7th Topic	8
SOFT WARE	--- 8th Topic	9
POCKET COMPUTER	--- 9th Topic	9
PC-1600	--- 10th Topic	15
HARD WARE	--- 11th Topic	7
SOFT WARE	--- 12th Topic (Last Topic)	9
		<u>118 (total)</u>

TOPIC NUMBER = 12  
 DATA LENGTH = 154 ( 118 + 12 + 12\*2 )  
 CONTENTS. END MARK. CONTROL CODE

•DISPLAY

```

MEETING
  ELECTRONIC ORGANIZER
    OZ-7000
    OZ-7100M
  POCKET COMPUTER
    PC-1600
    HARD WARE
    SOFT WARE
    
```

Attrib.	Length	Topic number	1st Topic (Title)	2nd Topic
003089413030303080433030808C4D454554494E470D0A818C454C454354524F4E4943204F5247	0019A000000C00		MEETING	ELECTRONIC ORG
			10**00001***1100	10**00011***1100
			control code	

3rd Topic	4th Topic	5th Topic
414E495A450D0A82884F5A2D37303030D0A83824841524420574152450D0A8312534F46542057415245		
ANIZE	OZ-7000	HARD WARE
		SOFT WARE
	10**00101***1000	10**00111***0010
		10**00111***0010

6th Topic	12th Topic (Last Topic)
0D0A82884F5A2D373130304D0D0A***534F4654	
OZ-7100M	SOFT
	SOFT WARE
	10**00111***0000
	10**00111***0000

NOTE) Mark "\*" of control code bit is not fixed yet.

2. Business Card

A. Business Card Data

303053484152500D0A504552534F4E41  
00 SHARP PERSONAL EQUIPMENT DIVISION ENGI

454E5420320D0A80373433352D332D353532310D0A8037343335  
NEERING DEPARTMENT 2 107435-3-5521 107435

2D322D383433350D0A843932204D494E4F53484F2D43484F2E20 414D412D  
-2-8435 492 MINOSH0-CHO. YAMATOKORIYAMA-

434954592C4E41 4A4150414E0D0A4E4F42 534849  
CITY, NARA 639-11 JAPAN NOBUTAKA TAKAHASHI

0D0A80373433352D332D353532390D0A53454E494F 4D45520D0A33300D0A  
107435-3-5529 SENIOR PROGRAMMER 30

54454E4E4953205348490D0A0D0A0D0A0D0A  
TENNIS SKI

B. Free Field Title

803041474520202020202020200D0A484F4242592020202020200D0A202020202020202020  
00 AGE HOBBY

0D0A202020202020202020200D0A202020202020202020200D0A

3. User's Dictionary

303053454E494F522050524F4752414D4D45520D0A  
00 SENIOR PROGRAMMER

## II PROTOCOL SAMPLE

### 1. Transferring Data From The Electric Organizer to Personal Computer

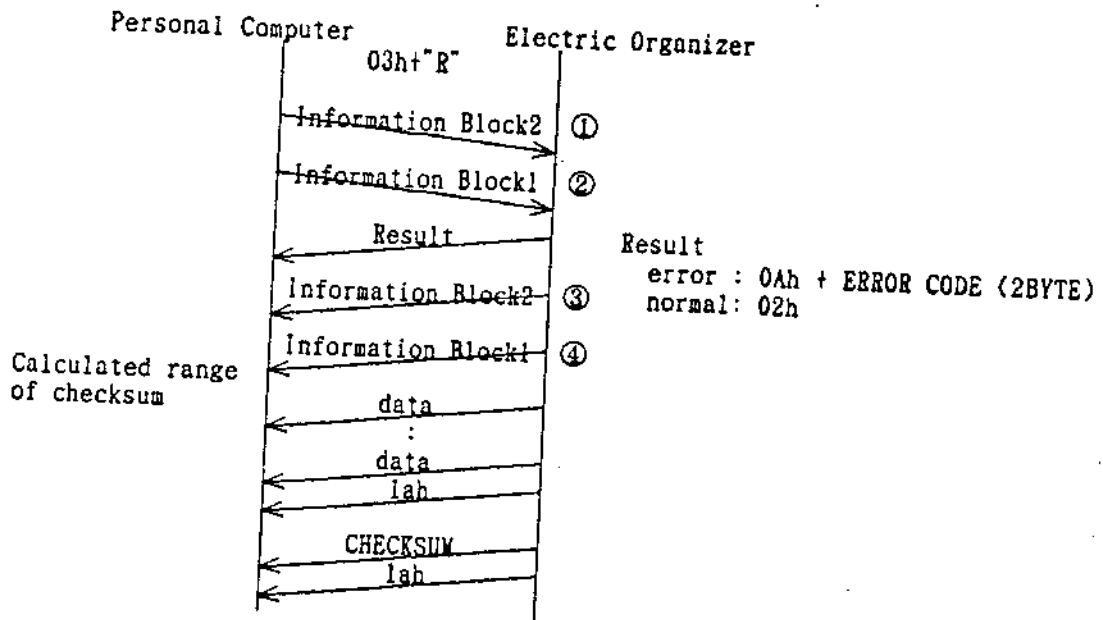

Information Block1 ② equal to Information Block1 ④  
 Information Block2 ① equal to Information Block2 ③

#### a. Transferring 3rd record in 10 records

Information Block1

3033303030300D0A4D454D4F20202020312020D0A
0 3 0 0 0 0      MEMO      1

Information Block2

303030300930330000093031B4353233303109D0A
0 0 0 0    0 3 0 0    0 1 4 5 2 3 0 1

Memo data

38304D454D4F2053414D504C452044415441310D0A
8 0 MEMO    SAMPLE    DATA 1

b. Transferring 3rd record ~ 7th record in 10 record

This data transfer protocol support one record transfer and application file transfer. In case of 3rd record ~ 7th record transfer Personal computer request one record transfer 5 times.

1st time transfer

Information Block1

3033303030300D0A	4D454D4F20202020312020D0A
030000	MEMO 1

Information Block2

303030300930330000093031343532333031090D0A
0000 0300 01452301

Memo data

88304D454D4F2053414D504C45204441544131D0A
80MEMO SAMPLE DATA 1

2nd time transfer

Information Block1

3033303030300D0A	4D454D4F20202020312020D0A
030000	MEMO 1

Information Block2

303030300930340000093031353633343032090D0A
0000 0400 01563402

Memo data

88304D454D4F2053414D504C45204441544132D0A
80MEMO SAMPLE DATA 2

5th time transfer

Information Block1

3033303030300D0A	4D454D4F20202020312020D0A
030000	MEMO 1

Information Block2

303030300930370000093031383936373035090D0A
0000 0700 01896705

Memo data

88304D454D4F2053414D504C45204441544135D0A
80MEMO SAMPLE DATA 5

2. Transferring Data From Personal Computer To Electric Organizer

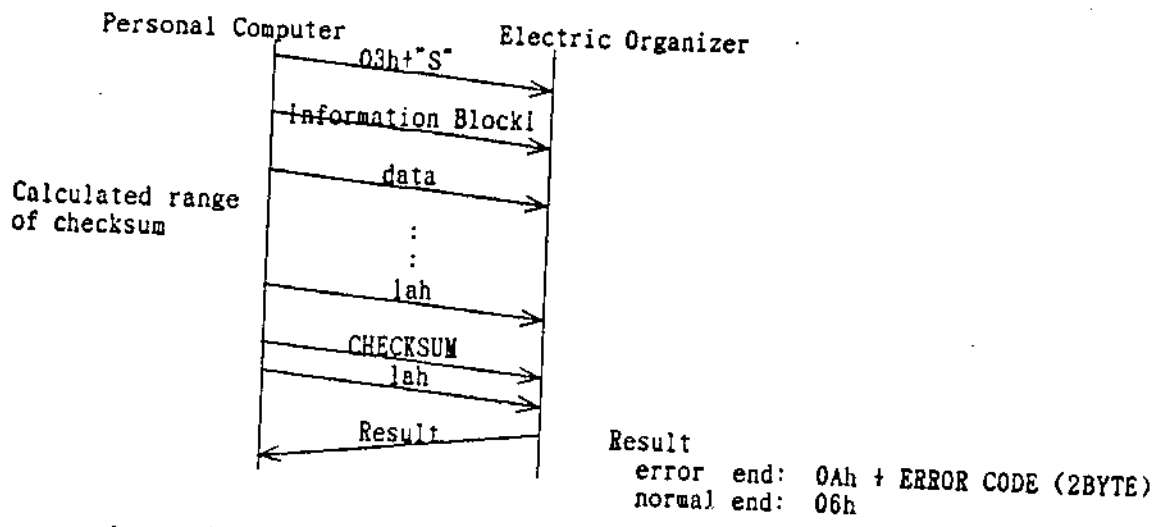

Level I protocol equal to Level II protocol.

a. Transferring 3 records to Electric Organizer

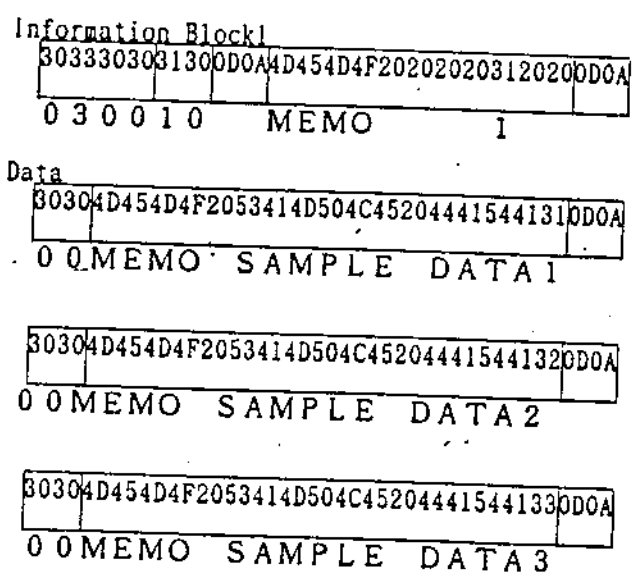



2) Data transmission (PC to Electronic Pocketbook) protocol

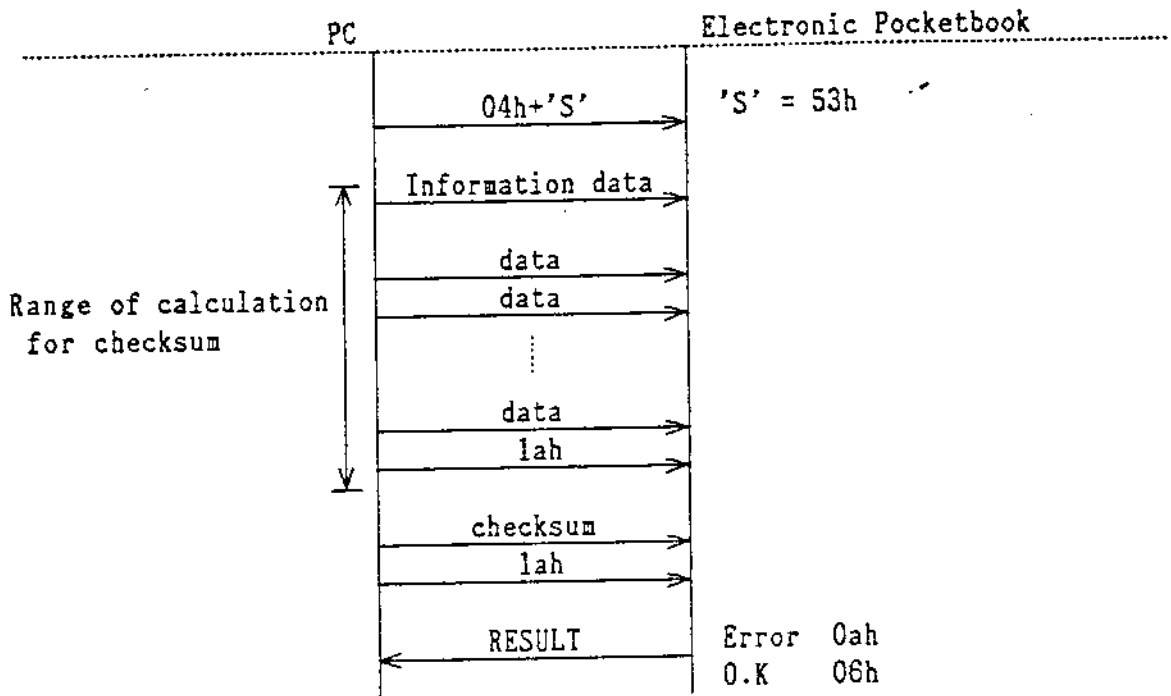

3) Data transmission (Electronic Pocketbook to PC) protocol

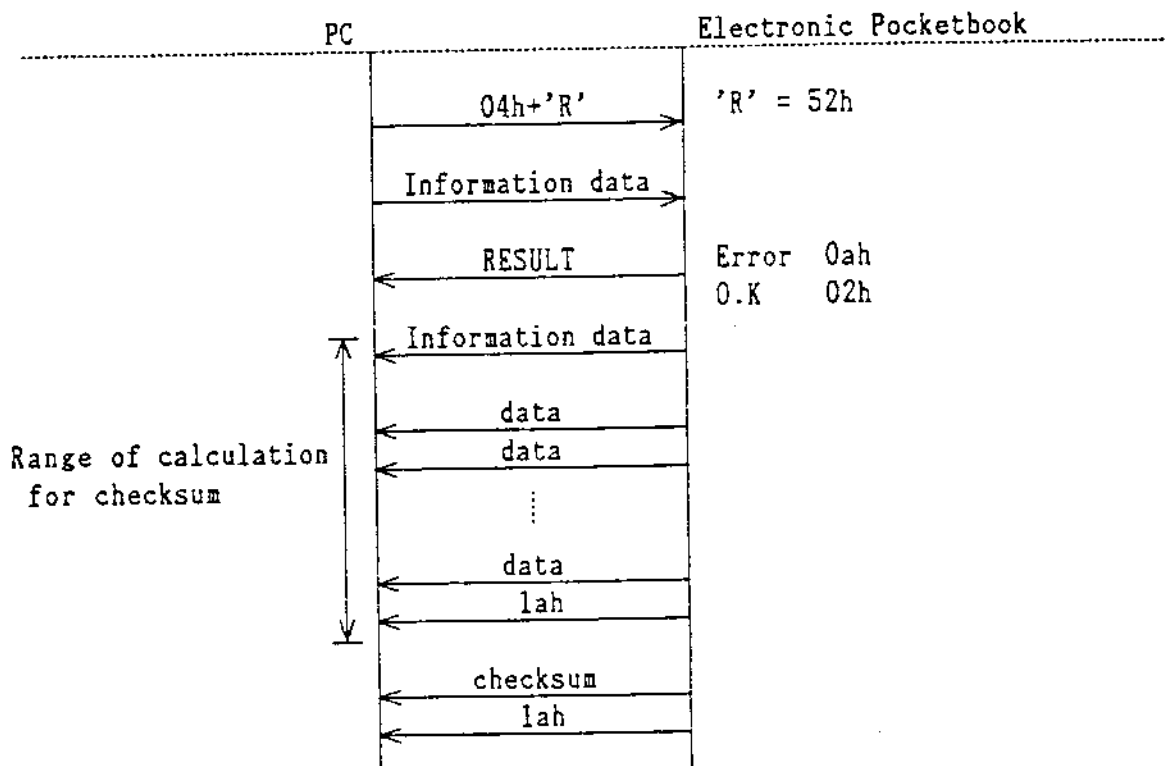

<Note> In case that the PC sends the data from the expanded RAM card even if it is not set on the Electronic Pocketbook, 02h+0ah will be returned to the PC from the Electronic Pocketbook as error information (RESULT). (Only 0ah is returned in the case of a normal error.) Therefore, the PC side should consider the following point (1) or (2).

- (1) Any data of the expanded RAM card must not be requested if it is not set on the Electronic Pocketbook.
- (2) Information on an error that has occurred during the data transmission from the Electronic Pocketbook to the PC must be checked in the following manner.

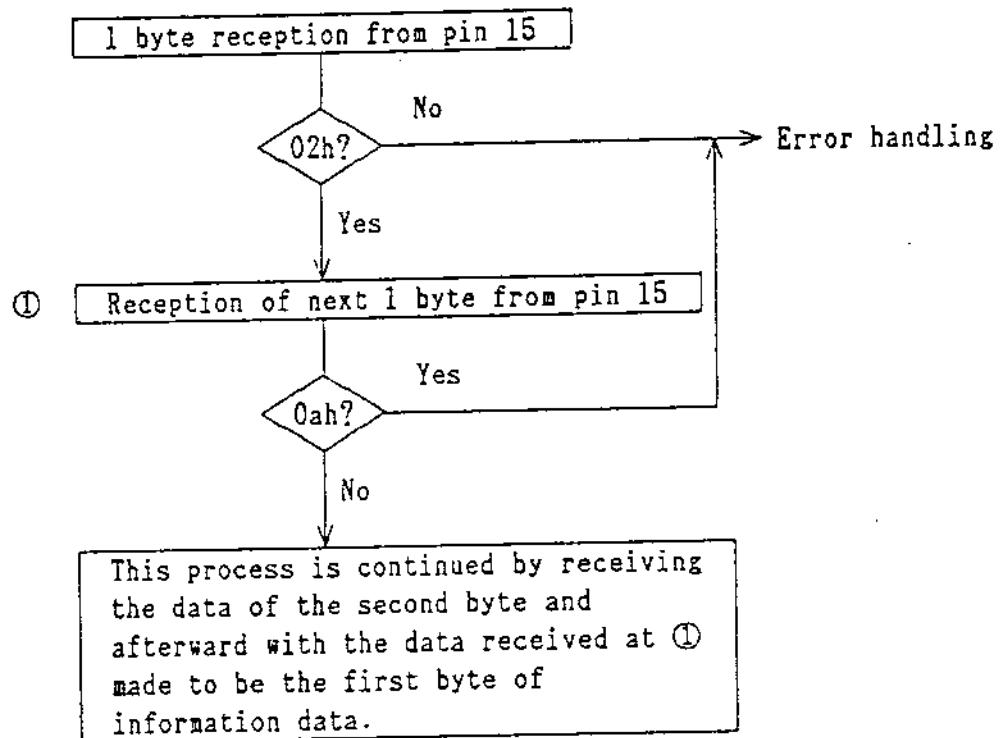

#### 4) End protocol for PC-LINK mode

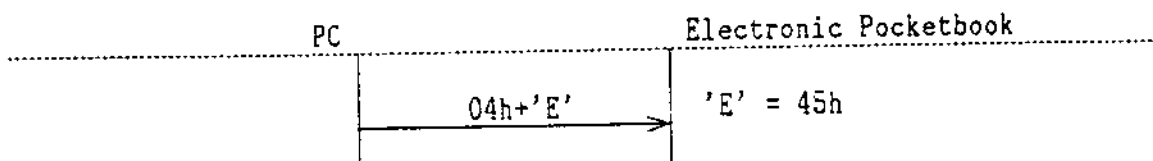

This terminates the PC-LINK mode of the Electronic Pocketbook.

<Note> The PC-LINK mode consumes much electricity from the battery. Therefore the PC-LINK mode should be terminated as soon as data transmission is over.

#### 5) Caution

If you fail to receive the data from the Electronic Pocketbook after waiting approximately 30 seconds under the protocols 1) to 3), you should get rid of the receive mode.

2-4-3. Processing outline of PC-LINK

- < OPTION >
- 1 PRINTER
  - 2 UNIT TO UNIT
  - 3 CASSETTE TAPE
  - 4 PC LINK

Note) \* In case where the application selected by PC does not exist

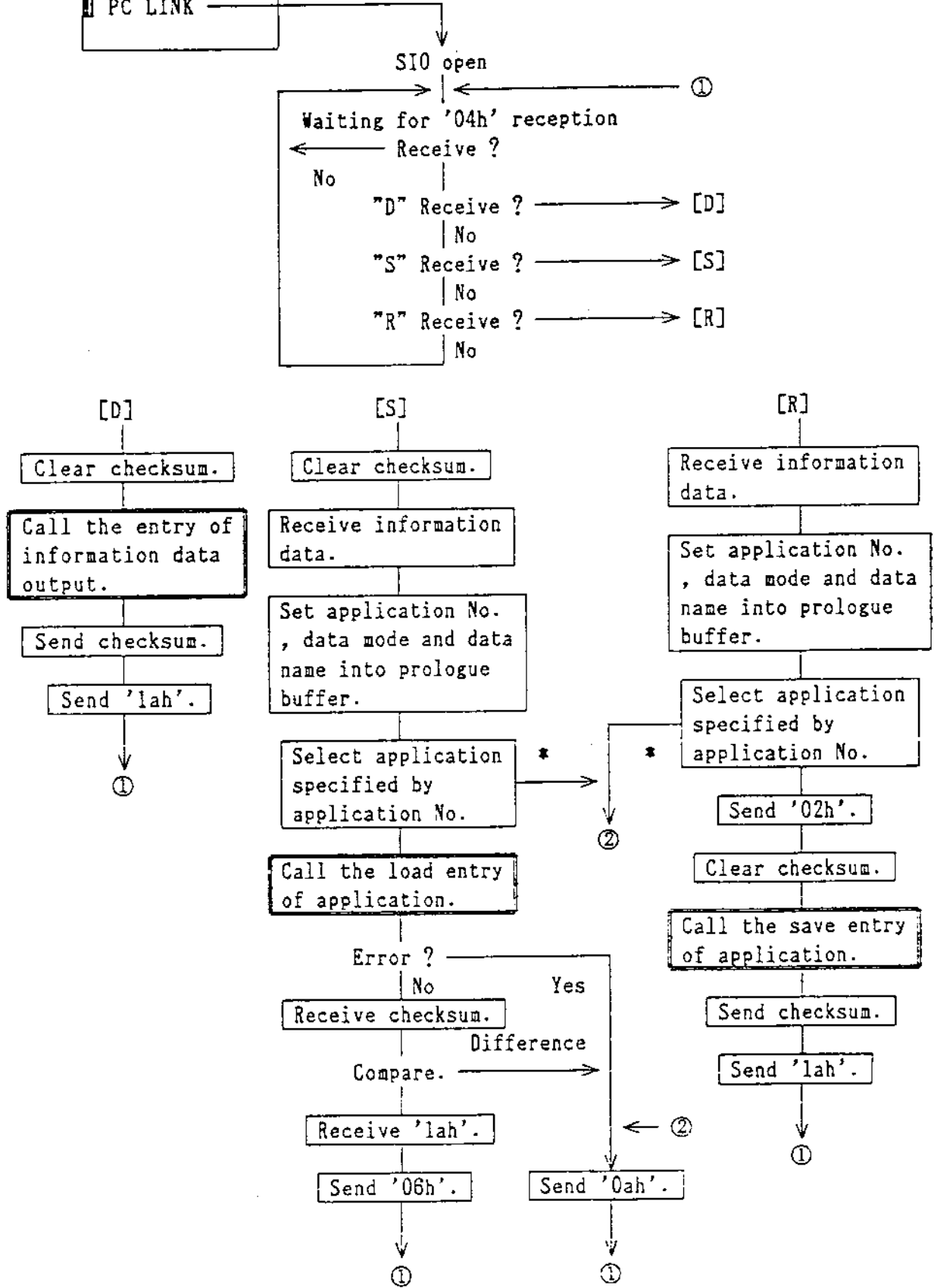

2-4-4. Contents of processing in application

1) Save processing (i=0006h and a=2 for entry)

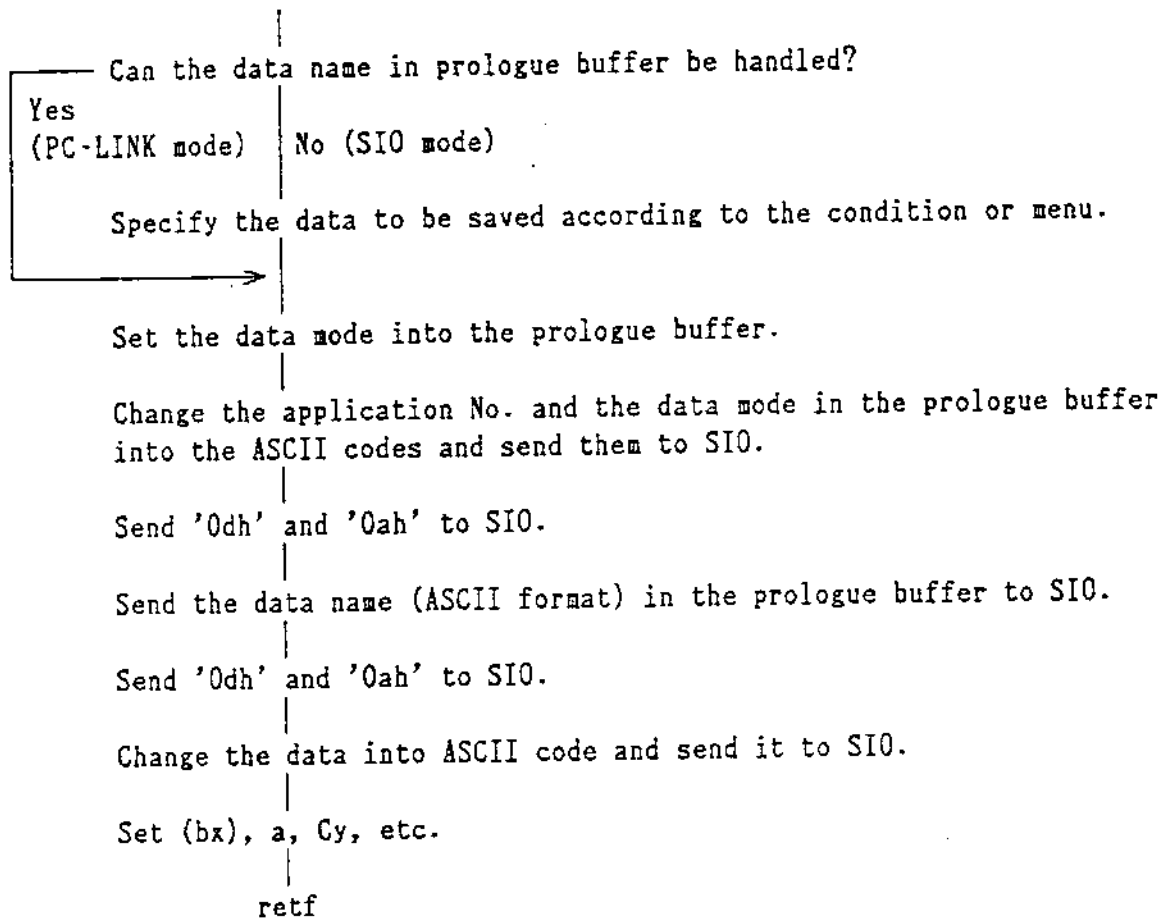

2) Load Processing (i=0007h and a=2 for entry)

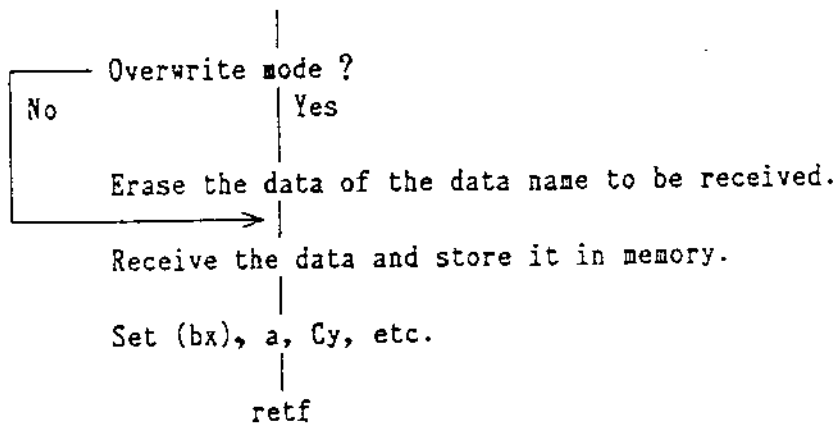

3) Verify processing (i=0009h and a=2 for entry)

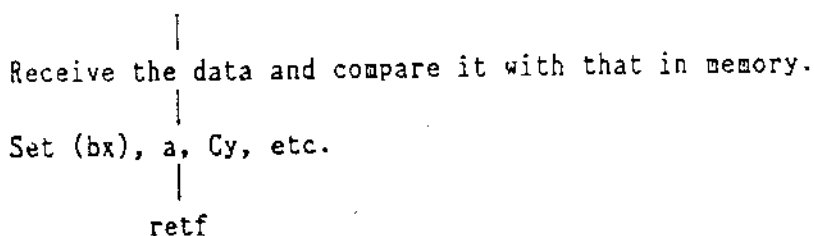

## 2-4-5. Data format

Input/output data format for PC-LINK is as follows:

Information data
Data (for one item)
Data (for one item)
⋮
Data (for one item)
lah

For information data, see 1-6, 2).

Checksum can be obtained by representing the lower 16 bits of the value to which the range specified above has been added byte by byte, in hexadecimal notation in order of Low and High and changing them into ASCII codes. Append 0dh and 0ah to the checksum.

Example) In case the checksum is 6b02h

30h	32h	38h	42h	0dh	0ah
'0'	'2'	'6'	'b'		

The data format of data (for one item) for PC-LINK is illustrated here through a concrete example of the main unit application data. The data is all ASCII formatted. Also, a number written above each data format shows a byte count of its item.

### 1) Telephone number

2										(bytes)
Attribute	Name	0dh	0ah	Telephone number	0dh	0ah	Address	0dh	0ah	

Note) Maximum 512 bytes are available for name, telephone number and address, including these three fields.

### 2) Memo

2			
Attribute	Content	0dh	0ah

Note) Maximum 512 bytes are available for the content of memo.

### 3) Schedule

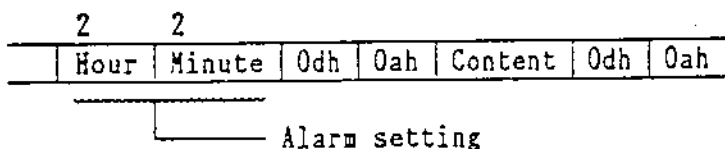
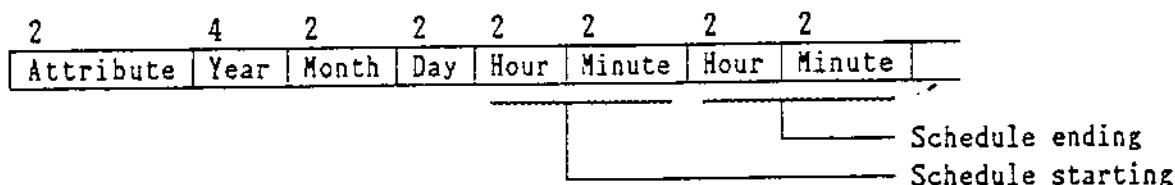

- Note) · When only 1 digit is used for month, day, hour or minute, each higher digit is occupied by '0'.
- If end time or alarm time is not set, space codes are placed instead of them.
  - Maximum 512 bytes are available for the content of schedule.

### 4) Anniversary 1

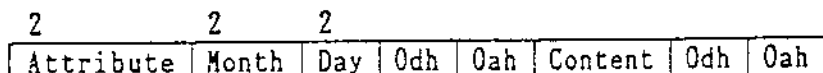

- Note) · When only 1 digit is used for month, day, hour or minute, each higher digit is occupied by '0'.
- Maximum 512 bytes are available for the content of anniversary.

### 5) Anniversary 2

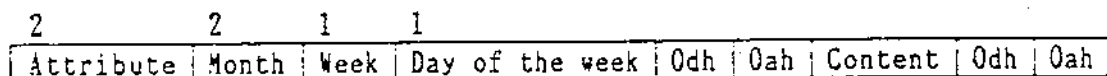

- Note) · When only 1 digit is used for month, day, hour or minute, each higher digit is occupied by '0'.
- A number from '1' to '5' is given to the week to indicate what week of the month the anniversary falls in.
  - A number from '0' to '6' is given to the days of the week as shown below:
    - Sunday '0'
    - Monday '1'
    - Tuesday '2'
    - Wednesday '3'
    - Thursday '4'
    - Friday '5'
    - Saturday '6'
  - Maximum 512 bytes are available for the content of anniversary.

- Attribute

Attributes in the data have following meaning. (In data transmission, data shown below are ASCII-coded.)

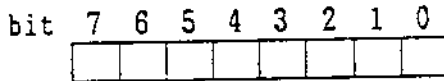

- bit 7: Shows presence or absence of secret mark (\*). Note 1)
  - 0: Secret mark Absent
  - 1: Secret mark Present
- 6: Shows presence or absence of alarm setting. Note 2)
  - 0: Alarm setting Absent
  - 1: Alarm setting Present
- 5: Shows display mode. Note 3)
  - 0: 8-line display
  - 1: 4-line display
- 4-0: 0

- Note 1) Meaningful in telephone directory, schedule and memo.
- Note 2) Meaningful only in schedule.
- Note 3) Meaningful in telephone directory, schedule, memo, anniversary 1 and anniversary 2.

For example, the attribute of the data with secret mark absent, alarm setting present, and 4-line display becomes '60h', so in the data it is represented by '36h' and '30h' (in ASCII format).

- Example of data

Shown below is the example of data for telephone directory. Suppose that the data is:

Name: Ben Smith  
 Telephone number: 123-456-7890  
 Address: New York

and that its attribute is '80h' (Secret mark present, 8-line display).

38h	30h	42h	65h	6eh	20h	53h	6dh	89h	74h	68h	0dh	0ah
'8'	'0'	'B'	'e'	'n'	' '	'S'	'm'	'i'	't'	'h'		
Attribute		Name										

31h	32h	33h	2dh	34h	35h	36h	2dh	37h	38h	39h	30h
'1'	'2'	'3'	'-'	'4'	'5'	'6'	'-'	'7'	'8'	'9'	'0'
Telephone number											

0dh	0ah	4eh	65h	77h	20h	59h	6fh	72h	6dh	0dh	0ah
		'N'	'e'	'w'	' '	'Y'	'o'	'r'	'k'		
Address											

## 2-5. SIO

### 2-5-1. SIO data transmitting procedures

- (1) Set the transmitting conditions of the PC and the Electronic Pocketbook so that they may agree with each other.
- (2) Set the receiving side in the 'ready to receive' state.
- (3) Set the sending side in the 'ready to send' state.

#### 1) How to set transmitting conditions

##### - Electronic Pocketbook

- (1) Press SHIFT+OPTION keys to activate option.  
(Option menu screen appears.)
- (2) Keyboard 'SIO' to select SIO. (SIO menu screen appears.)
- (3) Select FORMAT by pressing '1' key. (FORMAT screen appears.)
- (4) Select required items by means of '→' '←' '↑' and '↓' keys to set them. (Selected items are displayed in reverse video.)
- (5) Return to SIO menu screen by pressing 'C.CE' key.

##### - Personal computer

- (1) Set the conditions by means of "mode" command. (Do it in accordance with the setting method specified for each PC.)

#### 2) How to receive

##### - Electronic Pocketbook

- (1) Select the mode of the data to be received, and press SHIFT+OPTION keys to activate option.  
(Option menu screen appears.)
- (2) Keyboard 'SIO' to select SIO. (SIO menu screen appears.)
- (3) Get the 'ready to receive' state by pressing '3' key.  
("-RECEIVING-" appears on the screen.)

##### - Personal computer

- (1) Set copy, com1, 'file name', [ENTER]. (Do it in accordance with the operating method specified for each computer.)

### 3) Sending procedures

#### - Electronic Pocketbook

- (1) Select the mode of the data to be sent, and press SHIFT+OPTION keys to activate option. (Option menu screen appears.)
- (2) Keyboard 'SIO' to select SIO. (SIO menu screen appears.)
- (3) Get the 'ready to send' state by pressing '2' key. ("SENDING-" appears on the screen.)

#### - Personal computer

- (1) Set copy 'file name', com1 [ENTER]. (Do it in accordance with the operating method specified for each computer.)

### 2-5-2. Data format

The data format for SIO is the same as that for PC-LINK. But checksum is not present. (Refer to 2-4-5. Data format for PC-LINK.)

## 4-pin Interface

### 1. Transfer System Hardware Specification

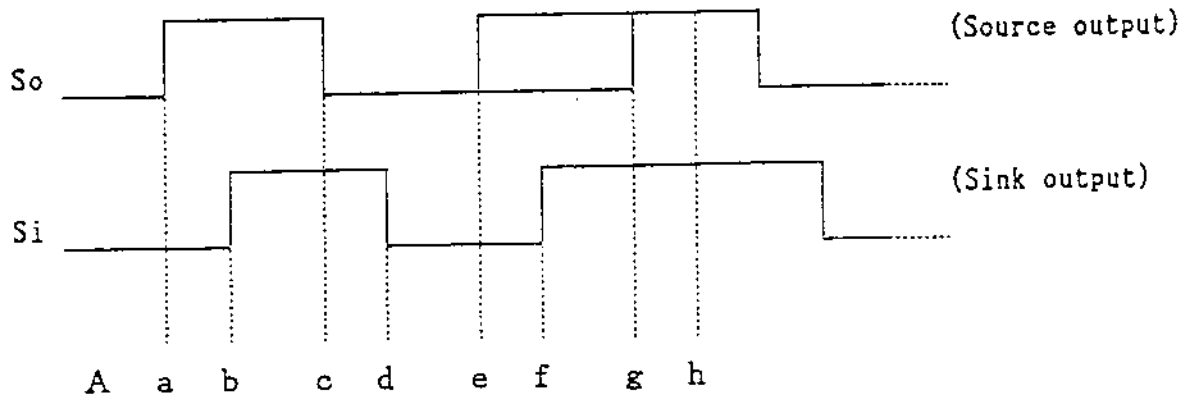

- A) The communication line is closed with signal Low at both the source and the sink.
- a) The source signal is made High to request the sink to make the line active.
- b) The sink receives the request and makes the line High to activate the line, so that the 4-pin line is activated.
- c) The source makes the signal Low to start data transfer.
- d) The sink is now ready for receiving data (1 bit) and makes the signal Low.
- e) The source then outputs 1-bit data.
- f) The sink takes in the data in a certain time and makes the signal High as the take-in completion signal.
- g) The source regards the data as having been received and makes the signal High.
- h) After the above steps, the following transfer procedure is started over from step c).

The communication line is closed when both the source and sink make the signals Low after transferring the data.

- Transmission speed : 1000 - 1200 bps (it varies with data to be processed)
- Transmission type : Half duplex communication
- Transmission method : Data length 8 bits  
Serial data, transfer from MSB

## 2. Timing specifications

### <Transmission>

(Signal viewed from source)

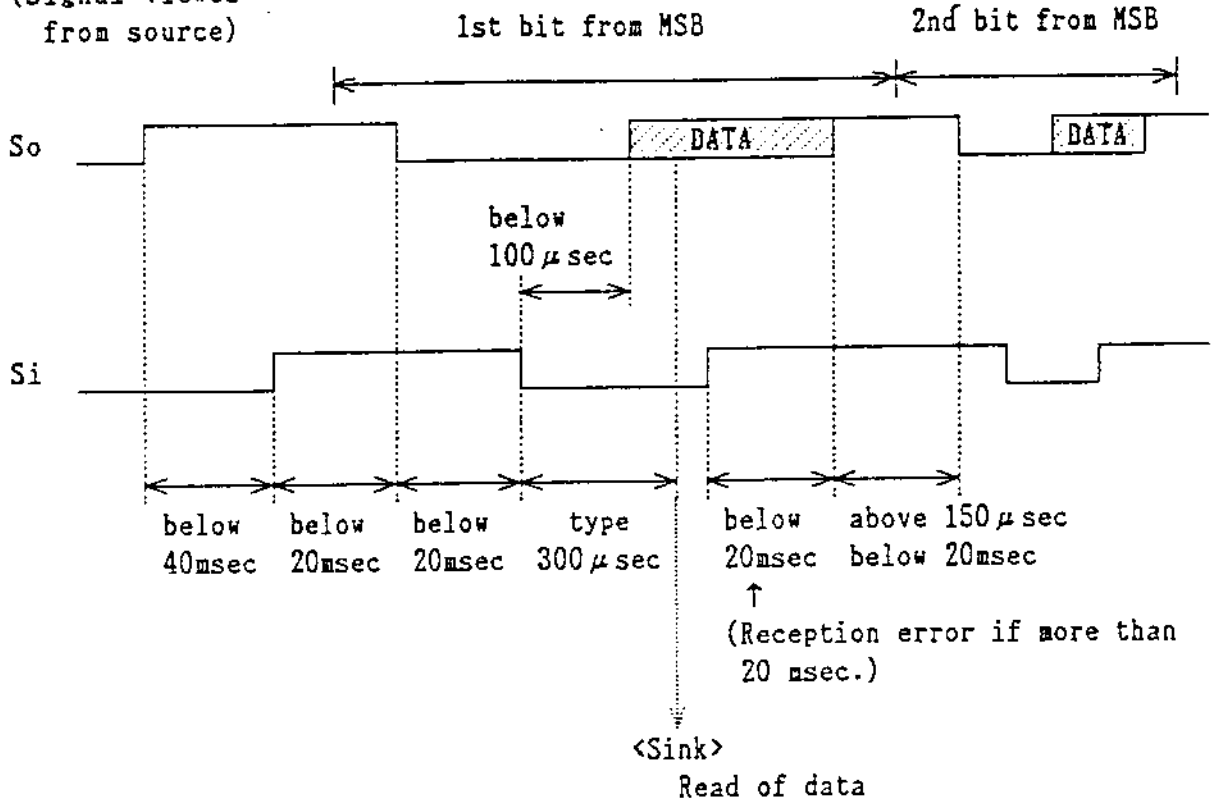

### <Transmission to reception>

When both So and Si are High, the next source is the one whose So becomes Low first.

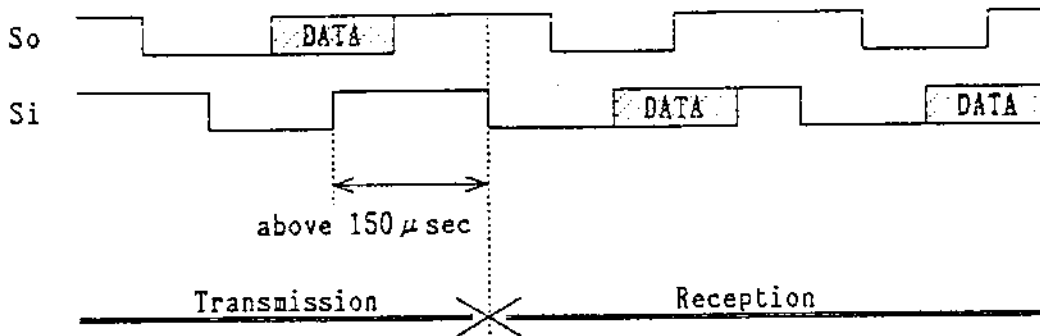

### • Example of data transfer

In the case of transferring 0a3h(10100011b) code

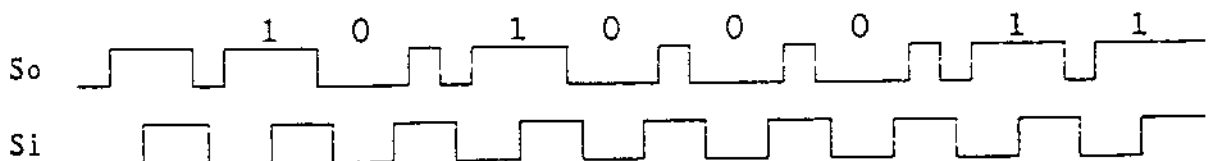

## 15-pin interface

### 1. Pin location

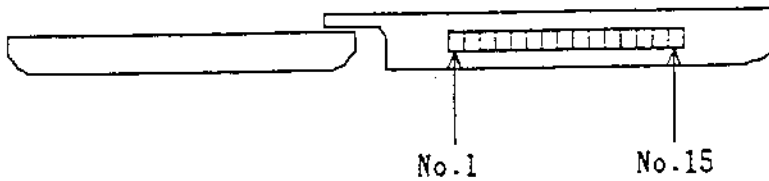

Pin No.	Name	Symbol	I/O	Function
1	Frame Ground	FG		Protective chassis ground
2	Send Data	SD	O	Outputs a DC data signal
3	Receive Data	RD	I	Inputs a DC data signal
4	Request to Send	RS	O	HIGH:Sends carrier
5	Clear to Send	CS	I	HIGH:Transmission enabled
6	Data Set Ready	DR	I	HIGH:Modem ready to send/receive
7	Signal Ground	SG		Reference 0 voltage for all signals
8	Carrier Detect	CD	I	HIGH:Carrier signal received
9				
10		VC1		Power supply
11	Receive Ready	RR	O	HIGH:Receive enabled
12				
13		VC2		Power supply
14	Data Terminal Ready	ER	O	HIGH:Local terminal ready
15				

#### <Notes>

- (1) HIGH: VC voltage level; LOW: SG voltage level.
- (2) OZ/IQ-7000 uses CMOS components. Application of voltage exceeding the allowable range, i.e., voltage level between SG and vc, may damaged the OZ/IQ-7000.
- (3) VC1, VC2 is connected in the unit.  
Voltage level is 3.8V-6.3V.

- 7) The file name is entered (Using this entered file name, the data is to be saved or loaded into or from the cassette tape recorder).
- 8) The CMT is opened for read or write.
- 9) - For a selection of RESTORE or BACKUP VERIFY, the machine reads information data (32 bytes) into the prologue buffer. If, at this point, the backup mode and the application card bit in the data mode are not found set, "DATA ERROR" is displayed.
  - For a selection of BACKUP, the machine operates as follows insofar as the application in the card runs:
    - The prologue buffer is cleared.
    - The application number is set to the prologue buffer.
    - The backup mode and the application card bit in the data mode are set.
    - The application is far called (i=0006h and a=1 as entry parameters). At this stage, "SAVING" is displayed.
    - When the application comes to an end, the machine sends an end code to the cassette tape.
  - For RESTORE or BACKUP VERIFY, the machine operates as follows:
    - If the application number in the prologue buffer does not agree with the application on the card side, "DATA ERROR" is displayed.
    - The application specified by the application number in the buffer is far-called (Entry parameters i=0007h and a=1 for RESTORE, and i=0009h and a=1 for BACKUP VERIFY).

This operation continues until the end code of the tape is reached. "LOADING" and "VERIFYING" are displayed at this time.
- 10) If an error occurs after the application is called, the error will be displayed.
- 11) The CMT is closed.

• When '4' is specified: (PC LINK)

- 1) The screen that appears on the display is:

<PC LINK>
LINK READY
TO QUIT
PUSH "ON" KEY

If the "ON" key is received here, the operation ends.  
 If '04h' is sent from the personal computer (PC) after the SIO is opened, the Electronic Pocketbook System is put in wait mode for an instruction to be sent from the PC. The machine then operates as follows according to the instruction sent by the PC:

- When "S" is sent from the PC, the machine:

- 2) Clears the checksum.
- 3) Receives the application number which is then set to the prologue buffer after binary-coded.
- 4) Receives the data mode which is then set to the prologue buffer after binary-coded.
- 5) Receives '0dh' and '0ah'.
- 6) Receives the data name and sets it to the prologue buffer.
- 7) Resumes the PC-LINK menu screen if there is not the application that agrees with the application number in the prologue buffer.
- 8) Far-calls the application specified by the application number in the prologue buffer (i=0007h and a=2 as entry parameters. The same as LOAD of the SIO).
- 9) If an error occurs after the application is called, the error will be displayed.
- 10) The checksum is then read and converted into binary code. If an error is found, the error is displayed.
- 11) The PC-LINK menu is resumed on the display.

- When "D" is sent from the PC, the machine:

- 2) Clears the checksum.
- 3) Far-calls the information data output routines of all the applications (i=000ah as entry parameter).
- 4) Sends 'lah'.
- 5) Converts the checksum into ASCII code and sends it.
- 6) Sends 'lah'.
- 7) Resumes the PC-LINK menu screen.

- When "R" is sent from the PC, the machine:

- 2) Receives the application number which is then binary-coded and set to the prologue buffer.
- 3) Receives the data mode which is then binary-coded and set to the prologue buffer.
- 4) Receives '0dh' and '0ah'.
- 5) Receives the data name, then sets it to the prologue buffer.
- 6) If there is not the application that agrees with the application number in the prologue buffer, the PC-LINK menu screen is resumed.
- 7) Sends '02h'.
- 8) Clears the checksum for send.
- 9) Far-calls the application specified by the application number set in the prologue buffer (i=0006h and a=2 as entry parameters. The same as SAVE of the SIO).
- 10) The PC-LINK menu is resumed.

• When 'SIO' is entered (SIO is selected):

1) When SIO is typed and entered on the OPTION menu, the following display appears:

```
<SIO>
1 FORMAT
2 SEND
3 RECEIVE
4 VERIFY
```

A selection of '1' is for communication format setting.

- When '2', '3', or '4' is selected:

- 2) - If the application does not have any data, the screen which was on the display before the keys SHIFT and OPTION were simultaneously operated is restored.
  - If it has data, the machine operates as follows:
- 3) It opens the SIO.
- 4) It then clears the prologue buffer.
- 5) - When SEND is selected, the machine:
  - Sets the application number to the prologue buffer, then far-calls the application (i=0006h and a=2 as entry parameters.) At this stage, "SENDING" is not on the display.
- When RECEIVE is selected, the machine:
  - Receives information data into the prologue buffer, and checks that the LOAD specifying bit in the data mode is set. If not found set, checks that the currently running application is the same as that loaded.
  - If they differ from each other, an error display appears.
  - Checks whether or not the overwrite mode is on. If it is on, checks data is cleared. If the data clearing is stopped here, the screen that was on before the keys SHIFT and OPTION were operated reappears.
  - If the LOAD specifying bit is not found set, the data name in the prologue buffer is cleared.
  - The application specified by the application number in the prologue buffer is far-called (i=0007h and a=2 as entry parameters). At this stage, "RECEIVING MODE" is on the display.
- When VERIFY is selected, the machine:
  - Receives information data into the prologue buffer, then checks that the currently running application is the same as the one loaded. If they differ from each other, an error display appears.
  - Clears the file name in the prologue buffer, then far-calls the application specified by the application number in the prologue buffer (i=0009h and a=2 as entry parameters).
- 6) For SEND, RECEIVE, and VERIFY, if an error occurs after the application is called, the error is displayed.
- 7) The SIO is closed.

Values returned by INPUT\$ (from keyboard):  
Byte 1

H \ L	0	1	2	3	4	5	6	7	8	9	A	B	C	D	E	F
0	*	space	@	1	2	3	4	5	6	7	8	9	A	B	C	D
1		!	"	#	\$	%	&	'	(	)	*	+	,	-	.	/
2	INS															
3																
4																
5																
6																
7																
8	BS															
9	J															
A																
B																
C	C-CE															
D	ENTER															
E																
F																

\* &H00 indicates the beginning of a 2-byte code.

The key operations listed in the following table cause INPUT\$ to return the following codes in the 2nd byte following &H00:

Byte 2

L \ H	0	1	2	3	4	5	6	7	8	9	A	B
0			OFF		CARD			SHIFT ^	MODE CHECK	PLAY BACK	SHIFT DRG	SHIFT PLAY BACK
1					WORLD			SHIFT v	BASIC	ANS	SHIFT BASIC	SHIFT #
2					LOCAL				STAT	(	SHIFT STAT	SHIFT -DEC
3									AER	)	SHIFT AER	SHIFT -HEX
4												
5												
6												
7												
8												
9												
A												
B												
C												
D												
E												
F												

Note:

ALARM EVENT (&H29) is the code returned when the schedule alarm sounds while waiting for a key to be pressed when the INPUT\$ command is being executed.

Die Übertragung von und zur Basic Card des Sharp IQ erfolgt blockweise. Als Handshake wird ein XON/XOFF Protokoll verwendet. Ein Block ist immer in die Steuerzeichen STX und ETX eingefaßt. Jeder Block ist zusätzlich mit einer Prüfsumme versehen. Die eigentlichen Daten in dem Block werden durch CTRL-Z von der Prüfsumme abgetrennt. Ein Block sieht also folgendermaßen aus:

STX, " ... Daten ... ", CTRL-Z, "xx", ETX

STX ist 02, ETX ist 03, CTRL-Z ist 1Ah. Die Prüfsumme ist zweistellig Hex in Ascii codiert (hier angedeutet durch "xx").

Wurde ein Block korrekt empfangen, so sendet der Empfänger ein ACK (06) zurück. Soll die Kontrolle an den Anderen übergeben werden, so wird ein 05 gesendet. Der Andere kann nun durch Senden von 05 die Kontrolle zurückgeben.

Die Checksumme wird gebildet aus dem eigentlichen Datenfeld incl. dem CTRL-Z, z.B.:

02,54,33,37,1A,44,38,03

$$54h + 33h + 37h + 1Ah = 0D8h$$

An Anfang der eigentlichen Daten steht meistens ein KommandoByte, das die Art der Daten beschreibt.

Bedeutung der KommandoBytes:

44h = 'D'  
38h = '8'

Basic Area senden:

PC->IQ "E1", filename(8+3)  
PC->IQ "G", datei

Dateiinfo senden:

PC->IQ "V", filename(8+3), "??????"ymunddhmmss

RAM Disk (S1) senden:

PC->IQ "E2", filename(8+3)  
PC->IQ "G", datei

Verzeichnis RAM Disk (E) abfragen

PC->IQ "A1"

RAM Disk (E) senden:

PC->IQ "F3", filename(8+3)

Data File senden:

PC->IQ "F4", filename(8+3) Immer DATA.BAS ???  
PC->IQ "G", datei

Basic area anhängen:

PC->IQ "E3", filename(8+3)  
PC->IQ "G", datei

Basic area empfangen:

PC->IQ "N1", filename(8+3)  
IQ->PC "N", datei

Vorher mit "I" abdecken, ob das Ding da ist

Verzeichnis RAM Disk (S1) abfragen:

PC->IQ "A0"  
IQ->PC "A", Einträge abgeschlossen durch CR/LF

RAM Disk (S1) empfangen:

PC->IQ "N2", filename(8+3)  
IQ->PC "N", datei

Verzeichnis RAM Disk (E) abfragen:

PC->IQ "A1"  
IQ->PC "A", Einträge abgeschlossen durch CR/LF

RAM Disk (E) empfangen:

PC->IQ "N3", filename(8+3)  
IQ->PC "N", datei



10/18 '1991

2/4

PC-LINK Interface of  
USER FILE and TO DO

"D" command is expanded in order to recognize the model of Organizers.  
Please send the command in the following order.  
It is possible to recognize the model by the response from Organizer.

• NEW PC-LINK PROTOCOL

- ① 03h+"d" (additional) OZ/IQ-8400, IQ-8500M  
When the Organizer receives this command, it returns "TO DO"  
application's name and other application's name.
- ② 03h+"D" OZ/IQ-8000, IQ-8100M  
OZ/IQ-8200, IQ-8300M

• OLD PC-LINK PROTOCOL

- ③ 04h+"d" (additional) OZ/IQ-7600, IQ-7700M  
OZ/IQ-7620, IQ-7720M  
When the Organizer receives this command, it returns  
"USERFILE" application's name and other application's name.
- ④ 04h+"D" OZ/IQ-7000, IQ-7100M  
OZ/IQ-7200, IQ-7300M  
ZQ-5xxx

• Protocol supported in each Organizer

	① 03h+"d"	② 03h+"D"	③ 04h+"d"	④ 04h+"D"
OZ/IQ-8400 IQ-8500M	○	○		○
OZ/IQ-8000 IQ-8100M		○		○
OZ/IQ-8200 IQ-8300M				○
OZ/IQ-7600 IQ-7700M			○	○
OZ/IQ-7620 IQ-7720M				○
OZ/IQ-7000 IQ-7100M				○
OZ/IQ-7200 IQ-7300M				○
ZQ-5xxx				

- The OZ/IQ-7000/7200, IQ-7100M/7300M have "OLD PC-LINK PROTOCOL".
- The OZ/IQ-7600/7620, IQ-7700M/7720M have "OLD PC-LINK PROTOCOL" and "Expanded OLD PC-LINK PROTOCOL".
- The OZ/IQ-8000/8200, IQ-8100M/8300M have "OLD PC LINK PROTOCOL" and "NEW PC LINK PROTOCOL".
- The OZ/IQ-8400, IQ-8500M have "OLD PC LINK PROTOCOL", "NEW PC LINK PROTOCOL" and "Expanded New PC LINK PROTOCOL".

• Additional applications in OZ/IQ-7600, 7700M, 8400, 8500M

Model	Application name	Application No.	Data Name (11 Bytes)
OZ/IQ-7600 IQ-7700M OZ/IQ-7620 IQ-7720M	USER FILE	2 F 0 0 h	USER _ _ _ _ 1 _ _ USER _ _ _ _ 2 _ _ USER _ _ _ _ 3 _ _
OZ/IQ-8400 IQ-8500M	T O D O	3 1 1 0 h	T O D O _ _ _ _ 1 _ _

" \_ " in Data Name means SPACE(20h).

• Application Numbers and Data name supported in each models

Application Name	Data Name (appli. No.)	OZ/IQ-8400 IQ-8500M	OZ/IQ-8000 OZ/IQ-8200 IQ-8100M IQ-8300M	OZ/IQ-7600 OZ/IQ-7620 IQ-7700M IQ-7720M	OZ/IQ-7000 OZ/IQ-7200 IQ-7100M IQ-7300M ZQ-5XXX
SCHEDULE1	SCHEDULE1	0110	○	○	○
PERIOD SCHEDULE	PERIOD 1	0110	○	○	○
ANNIVERSARY1	ANN 1	0110	○	○	○
ANNIVERSARY2	ANN 2	0110	○	○	○
DAILY ALARM	D ALARM 1	0110	○	○	○
TEL FILE NAME	TEL FILE1	0200	○	○	○
TEL FREE TITLE	TEL FREE1	0200	○	○	○
TEL1	TEL 1	0200	○	○	○
TEL2	TEL 2	0200	○	○	○
TEL3	TEL 3	0200	○	○	○
MEMO1	MEMO 1	0300	○	○	○
OUTLINE	OUTLINE 1	1D00	○	○	○
BUSI FREE TITLE	BUS FREE1	1E00	○	○	○
BUSINESS CARD	BUSINESS1	1E00	○	○	○
USER'S DIC.	USER'S DIC	1F00	○	○	○
USER FILE1	USER 1	2F00	○	○	○
USER FILE2	USER 2	2F00	○	○	○
USER FILE3	USER 3	2F00	○	○	○
TQ DO	TOD0 1	3110	○	○	○

• USER FILE Data format

• Information Block1

The structure of Information Block1 is same as current PC-LINK format. Application No. and Data Name used in Information Block1 are mentioned in the upper figure.

• Data Format

• The control data is necessary at the top of USER FILE's data.

DATA FORMAT in case of a few data transmitting

Control DATA
DATA 1
DATA 2
DATA 3
:
:
DATA N

DATA FORMAT in case of one data transmitting

Control DATA
DATA

4/4

• CONTROL DATA FORMAT

Attrib.	TITLE	09	FIELD NAME 1	09	FIELD NAME 2	09	...	FIELD NAME 16	09	00	0a
---------	-------	----	--------------	----	--------------	----	-----	---------------	----	----	----

Attribute : 2 bytes  
 This code means that the DISPLAY FIELD NAMES is set or not.  
 "00" : NO  
 "80" : YES  
 TITLE : 1 0 Bytes fixed  
 USER FILE NAME is set in this area.  
 FIELD NAME 1 ~ 16: 1 2 Bytes fixed

(Note) When data is downloaded in append mode from PC to Organizer, organizer ignores this control code. In another words, USER FILE NAME and FIELD NAME which are already set in Organizer are not changed.

• DATA FORMAT

Attrib.	FREE FIELD 1	09	FREE FIELD 2	09	...	FREE FIELD 16	09	00	0a
---------	--------------	----	--------------	----	-----	---------------	----	----	----

2 Max 512Bytes+16Bytes(the numbers of 09h)

Attribute : 2 Bytes  
 "00" : Non Secret DATA  
 "80" : Secert DATA

FREE FIELD 1 ~ 16: DATA of each field.  
 (Note) In case of no data in field, only 09h is transmitted.

• TO DO Data Format

• The structure of Information Block1 and Information Block2 is same as NEW PC-LINK format.  
 Application No. and Data Name are mentined in the upper figure.

• Data Format

Attrib.	year	month	day	20h	20h	20h	20h	20h	Description	...
2	4	2	2	1	Priority			12	12	12
	12	12	12	12	12	12	12	12	12	12

Attribute : 2 Bytes  
 Bit 7 Secret mark 1: Secret data  
 0: Non secret data  
 Bit 6 Not used  
 Bit 5 Display mode 1: 4-line display  
 0: 8-line display  
 Bit 4 ~ Bit 0 Not used

Year, Month, Day : Year 4 Bytes Month 2 Bytes Day 2 Bytes  
 (Due date)

Priority : 1 Bytes  
 0 ~ 9 (30h~39h) , A ~ Z (41h~5ah) , Space (20h)  
 c 5 h (Check mark)

Discription : max 2 0 4 8 Bytes  
 Category 1~5 : 1 2 Bytes Fixed  
 In case of no Category, only 0dh, 0ah are followed.

## 2. IQ-791A/792A Organizer Link

When uploading data from the IQ-8000 Organizer to a PC using the IQ-791A or IQ-792A, there are the following restrictions:

- Entries up to 512 characters can be transferred. Entries exceeding 512 characters will be ignored and thus will not be transferred.
  - None of the FREE FIELD entries stored in the TEL mode can be transferred.
  - None of the entries stored in the OUTLINE or BUSINESS CARD mode can be transferred.
  - ANN1 or ANN2 entries in the ANN (PERIOD) mode can be handled the same as with the IQ-7000 series.
3. When applying the RAM card (in an almost Memory Full condition) used in an IQ-7000 series Organizer, there are the following restrictions:
- If the CARD key is pressed in the OUTLINE or BUSINESS CARD mode, a message "MEMORY FULL" will appear and thus the CARD function cannot be used.
  - In the TEL mode, no NAME entry for any of the free fields can be stored (on the CARD side).
4. Caution required when Secret mode is ON in the Terminal mode.
- The Remote Function with MODEM LINK will not work.
5. With the IQ-8000 series Organizers, the IQ-709A Organizer Talk cannot be used.
6. With the main memory of the Organizer being full of data, any of the entries stored in the BUSINESS CARD mode cannot be edited. (If you delete or overwrite part of an entry in the EDIT mode and press ENTER a message "MEMORY FULL" will appear and the edit operation cannot be performed. The entry will remain the same as before the edit operation).
7. If you install the RAM card used in an IQ-8000 series Organizer in an IQ-7000 series unit and check the card memory capacity, the capacity of free areas may not be correctly displayed.
- 
8. While the IQ-705A (Money Planner Card) is in use in this Organizer, the CLIP and TIME/DATE functions of the Organizer cannot be used.

### ALLOCATION OF FREE FIELD NAMES

- In the TEL and BUSINESS CARD modes, FREE FIELD NAMES must be entered in the order of FREE FIELD 1 to 5 without skipping.  
If you should skip a number in the entering order of the FREE FIELD names, this may result in a loss of data within the Organizer.
- In the TEL and BUSINESS CARD modes, when deleting a FREE FIELD NAME which has been entered.
  - 1 Select the FREE FIELD NAME entry display screen.
  - 2 Select the FREE FIELD NAME to be deleted by pressing the ENTER key.
  - 3 Type in "FREE [SPACE] FIELD [SPACE] # [ENTER]".  
(# relates to the number of the FREE FIELD to be deleted).
  - 4 Press [C.EE] twice.
  - 5 FREE FIELD names should now be entered WITHOUT skipping.

SUPPLEMENT TO THE IQ-8000/IQ-8200 OPERATION MANUAL

1. Conditions under which data on an IQ-8000 series Organizer can be used on an IQ-7000 series Organizer.

(1) UNIT TO UNIT function:

The entries stored in the MEMO, TEL, and SCHEDULE modes can be transferred but with the following restrictions:

- Maximum number of characters that can be displayed and edited

MEMO mode: Entries  $<$  512 characters  
TEL mode: Entries  $\leq$  507 characters

The entries exceeding the above character length limit for each mode can be displayed on any of the IQ-7000 series units. However, these entries cannot be edited.

SCHEDULE mode: Entry  $\leq$  512 characters

The entries exceeding the above character length limit can be neither displayed nor edited on any of the IQ-7000 series units.

- Maximum number of characters that can be transferred per entry

MEMO mode: Entry  $<$  1,474 characters  
TEL mode: Entry  $\leq$  1,461 characters  
SCHEDULE mode: Entry  $\leq$  1,474 characters

In the transfer of a single entry, if you attempt to transfer the entry exceeding the above character length limit, an error message "MEMORY FULL ERROR" will appear.

(2) RAM CARD function

The entries stored in the RAM card (MEMO, TEL and SCHEDULE modes) can be used but with the following restrictions:

- Maximum number of characters that can be displayed and edited

MEMO mode: Entries  $<$  512 characters  
TEL mode: Entries  $\leq$  507 characters

The entries exceeding the above character length limit for each mode can be displayed on any of the IQ-7000 series units. However, these entries cannot be edited.

SCHEDULE mode: Entries  $\leq$  512 characters

The entries exceeding the above character length limit can be neither displayed nor edited on any of the IQ-7000 series units.

CHARACTER CODE FOR DISPLAY

L/H	0	1	2	3	4	5	6	7	8	9	A	B	C	D	E	F
0	◀	□	0	@	P	'	p	ç	é	á	À	AM	0	α	≡	
1	▶	□	!	1	A	Q	a	q	ü	æ	í	E	PM	1	β	≡
2	◀	□	"	2	B	R	b	r	é	Æ	ó	Ö	PM	2	Γ	≡
3	▶	□	#	3	C	S	c	s	â	ô	ú	Á	PM	3	π	≡
4	◀	□	\$	4	D	T	d	t	ä	ö	ñ	í	PM	4	Σ	≡
5	▶	□	%	5	E	U	e	u	à	ò	Ñ	Ú	✓	5	σ	≡
6	◀	□	&	6	F	V	f	v	å	û	æ	Ó	H	6	μ	÷
7	▶	□	'	7	G	W	g	w	ç	ü	ó	À	PM	7	τ	≈
8	◀	□	(	8	H	X	h	x	ê	ÿ	ç	Ê	ü	8	Φ	°
9	▶	□	)	9	I	Y	i	y	ë	ö	ã	Ô	..	9	θ	•
A	◀	□	*	:	J	Z	j	z	è	Ü	À	ó	^	X	Ω	•
B	▶	□	+	;	K	[	k	{	ï	φ	½	Ö	˘	§	δ	√
C	◀	□	,	<	L	\	l	;	î	£	¼	ø	˘	!!	∞	n
D	▶	□	...	-	=	M	J	m	}	ì	≠	í	ø	~	→	φ <sup>2</sup>
E	◀	□	.	>	N	^	n	~	Ä	ρ	«	£	°	←	∈	■
F	▶	□	/	?	O	-	o		Å	f	»	£	-	◇	∩	



This has different character according to display size (5x7 or 8x6 dot)



Character to display calendar